



TMC-150/300/500

Vacuum Tumbling Machine

Operation Manual

Version 6.9.1

1915 E. Acacia Street, Ontario, CA91761, U.S.A

TEL : 1-909-923-3888

FAX : 1-909-923-3588

<http://www.promarksvac.com>

S/N:

QC SIGNATURE:

TABLE OF CONTENTS

1. INSTALLATION	1
2. MAINTENANCE	1
3. FUNCTIONS OPERATION.....	1
4. MACHINE SPECIFICATION.....	2
5. MACHINE OPERATION EXPLAIN....	3
6. FABRICATION	4
6.1 DRUM BODY.....	5-6
6.2 MACHINE CASE.....	7-10
6.3 ELECTRICAL BOX	11-12

1. INSTALLATION

Please check the electric power listed on the vacuum pump and install the vacuum pump correctly,
ground line must on the floor.

2. MAINTENANCE

- A. To ensure vacuum pump works smoothly suggest change the vacuum oil every 500 working hours or every a half year.
- B. Check water filter bottle everyday, as soon as the water over a half of the bottle please cleans it.

3. FUNCTIONS AND OPERATIONS

- 1 Mix time
- 2 Barrel speed
- 3 Vacuum
- 4 Vacuum pump ON/OFF switch
- 5 Tumble ON/OFF switch
- 6 Inch moving tumble forward/Reverse

Cleaning. The tumbler inside must be cleaned everyday after working hours.

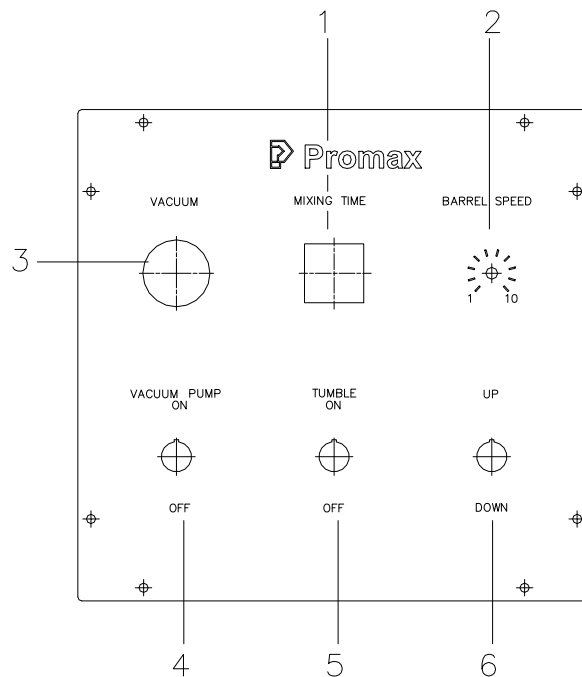

4. MACHINE SPECIFICATION

Model	W	L	H	A	B	C	Capacity
TMC-150	1207(48")	940(37")	1378(54")	675(27")	∅545(22")	832(33")	75Kg
TMC-300	1392(55")	940(37")	1520(60")	860(34")	∅670(27")	850(33")	135Kg
TMC-500	1392(55")	940(37")	1610(63")	860(34")	∅860(34")	765(30")	300Kg

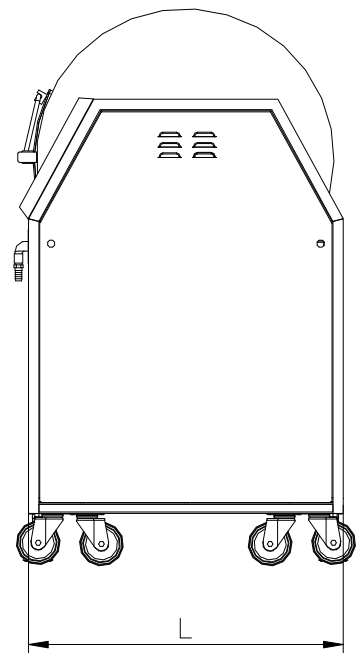
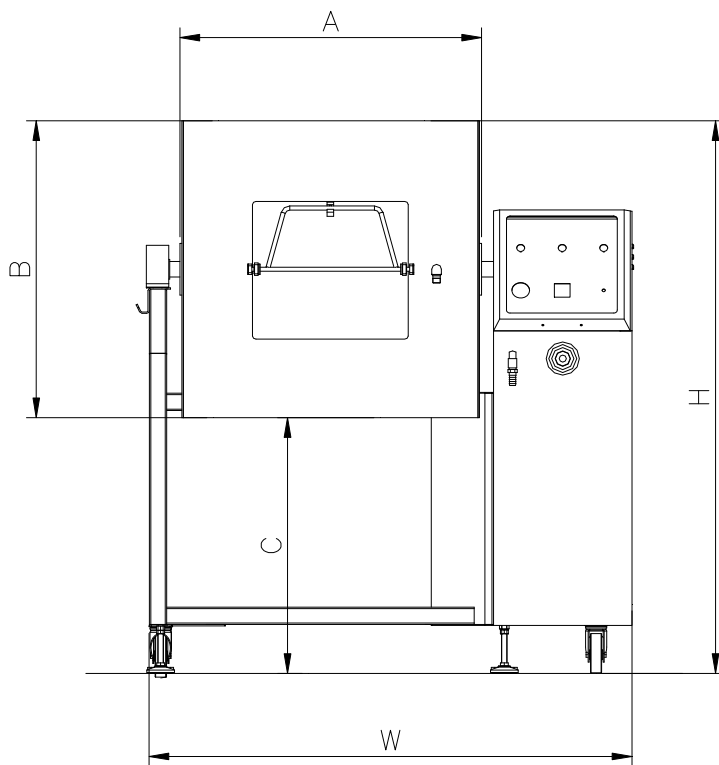
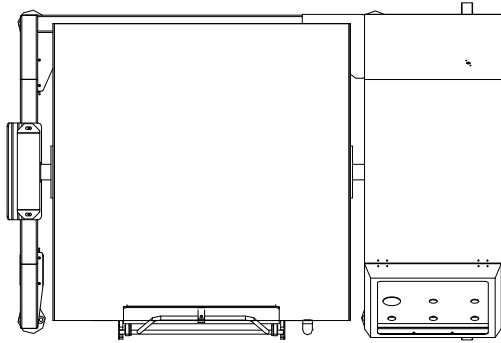

5.MACHINE OPERATION EXPLAIN.

Check the right power source with the name plate of the machine. Plug in the power and ready to operate the machine.

Turn on main power switch and set the value on control panel. After finish all of the setting push down the safety bar and press “Start/Pause” button to start the function. Safety function will be effective and machine will stop at the same time while user pull up the safety bar or gear motor box during working process.

After vacuum tumbling job finish, machine will stop and air ventilation at the same time. As soon as machine finish air ventilation, open the vacuum cover and use unloading switch to unload the product in drum.

The stopper on the side of the machine is design to hold the drum and remain it in the same angle and help user to load in the processing product. How to use the stopper:

- A. Push in the handle bar of stopper to the hole of the drum before load in the processing product.
- B. Pull back the handle bar of stopper from the hole of the drum before start the machine.

Warning: The handle bar of the stopper must be pulled back before user start the machine!! The machine will be damaged if user have not fulfill it!!

6. FABRICATION

6.1 DRUM BODY

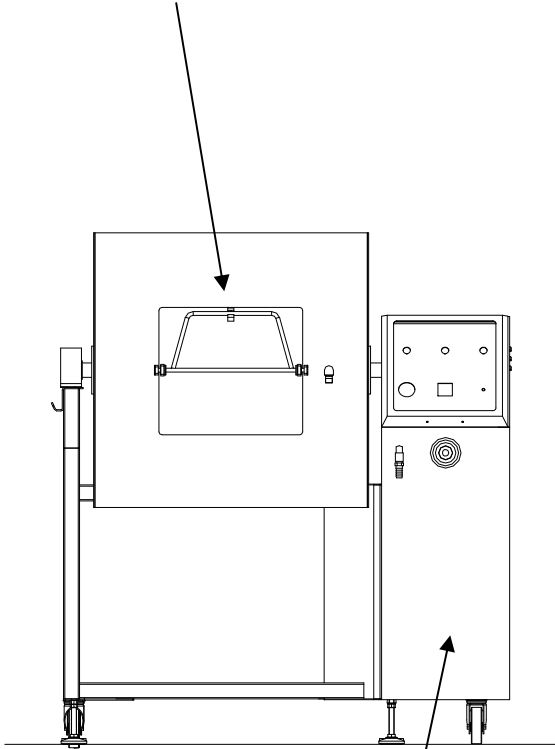

6.2 MACHINE CASE

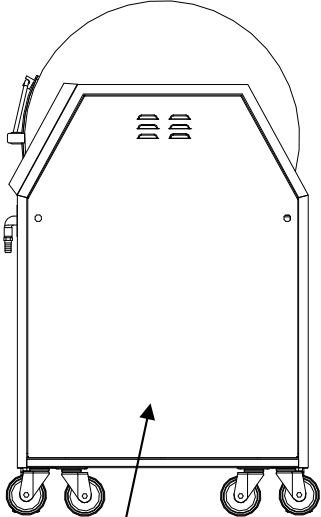

6.3 ELECTRICAL BOX

6.1 DRUM BODY

Drum Body Diagram

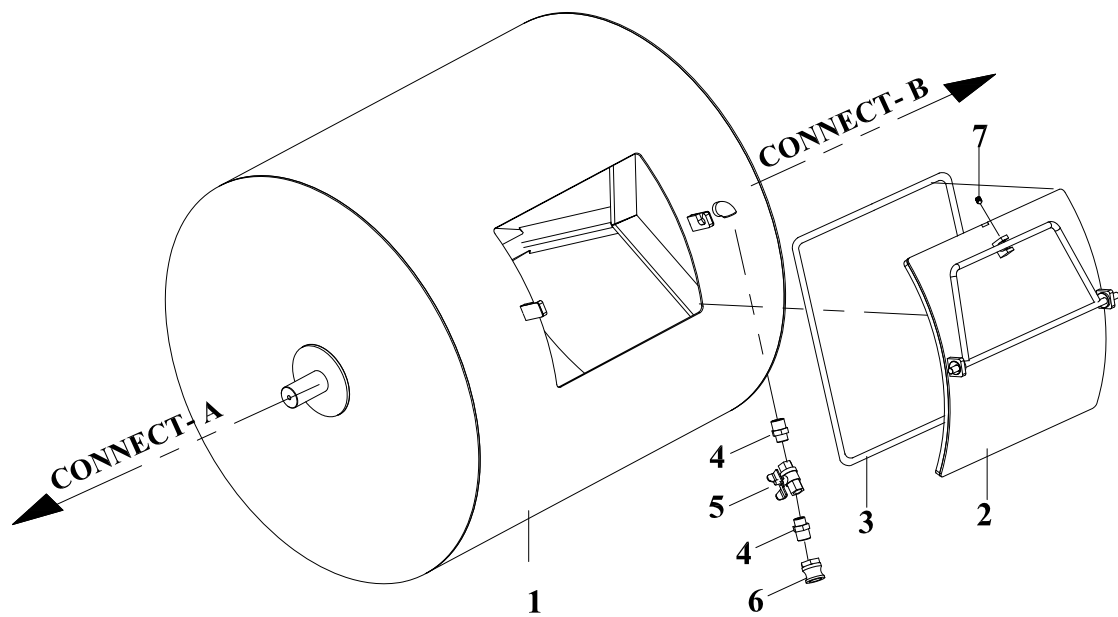

TMC5010000

6.2 MACHINE CASE DIAGRAM

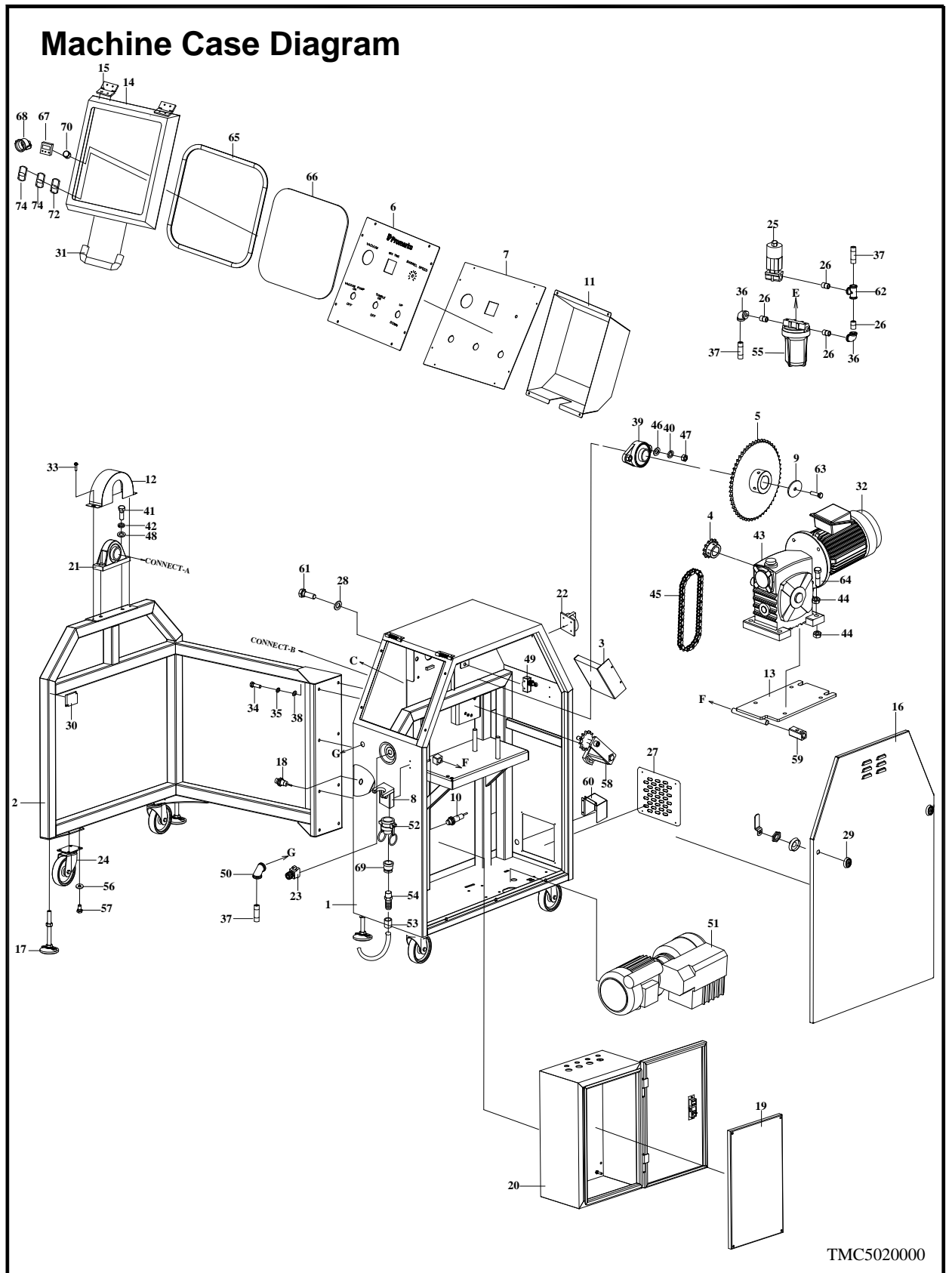

NO.	PART NO.	DESCRIPTION	QTY	NOTES
1	MC15101000	Frame(TMC150)		OPTION
	MC50101002	Frame(TMC300,TMC500)	1	
2	MC15102000	Side frame(TMC150)	1	OPTION
	MC50102000	Side frame(TMC300.TMC500)	1	
3	TM5H116000	Electrical protect plate	1	
4	MC50106001	Chain wheel	1	
5	MC50107000	Chain wheel	1	
6	MC50109001	Control panel plate	1	
7	MC50110001	Control panel bottom plate	1	
8	MC50111005	Fixed plate	1	
9	MC50118000	Pad	1	
10	2851407	Sensor	1	
11	MC50129000	Cover plate	1	
12	TM3H139000	Cover plate	1	
13	MC50122001	Motor fixed plate	1	
14	TM3H130012	Control panel cover plate	1	
15	28831391	Hinge	2	
16	TM3H190000	Side door	1	
17	2712222	Base leg	4	
18	2850613	Sensor	1	
19	TM3H803000	Panel	1	
20	TM3H801000	Electrical box	1	
21	2728537	Bearing pillow blockUCP209	1	
22	28017051	Switch	1	
23	2870077	Switch M22EL-TSF20E30	1	
24	27121411	Casters 4"	4	
25	29118085	Valve VXZ2242-04-BGR1(AC24V)	1	
26	290932570	Nipple 1/2"x30	3	
27	TM3H145000	Cover plate	2	
28	2705329	Flat washer M16	2	
29	2883349	Door lock C408K	2	
30	28501030	Reflector	1	
31	2883343	Hinge	1	

NO.	PART NO.	DESCRIPTION	QTY	NOTES
32	2814532	Motor 1HP/4P/3 ψ 230/460V 50/60HZ	1	
33	2701501	Round head screw M6x12(S)	2	
34	27004001	Hex head screw M10x20(S)	8	
35	2705304	Split lock washer M10(S)	8	
36	274000661	Elbow 1/2"	2	
37	290932569	Nipple 1/2"x60	3	
38	2705189	Flat washer M10(S)	6	
39	27285281	Bearing pillow block UCFL209	1	
40	2705328	Split lock washer M16(S)	4	
41	270020290	Hex head screw M16x45(S)	2	
42	2705322	Split lock washer M14(S)	4	
43	2815288	Decelerator LM-HMW-80-60-R-1HP	1	
44	27070094	Nut M14 (S)	8	
45	2713024-34	Chain RS50(TMC150)	1	OPTION
	2713024-38	Chain RS50(TMC300,TMC500)	1	
46	2705329	Flat washer M16 (S)	2	
47	27071103	Nut M16 (S)	2	
48	2705155	Flat washer M14 (S)	2	
49	2853313	Limit switch TZ-7311	1	
50	2909262	Bend 1/2" (S)	2	
51	2961059	Vacuum pump 1 ψ	1	OPTION
	2961063	Vacuum pump 3 ψ	1	
52	29093291	Fitting TYPE B 3/4"	1	
53	MC50124A00	Connection 1/2"	1	
54	2909238	Fitting	2	
55	2940011	Filter bottle	1	
56	2705151	Flat washer M6(S)	16	
57	2700402	Hex head screw M6x16(S)	16	
58	2714250	Chain wheel plate RSC-45-50S	1	
59	MC50121000	Fixed mount	1	
60	MC50123000	Cover plate	1	
61	270020291	Hex head screw M16x35(S)	3	
62	29090097	Tee branch valve 1/2"(S)	1	
63	27004004	Hex head screw M10x30(S)	1	
64	27004560	Hex head screw M14x40(S)	4	
65	2714752	Gasket L=1230	1	
66	TM3H130021	Window	1	

6.3 ELECTRICAL DIAGRAM (110V)

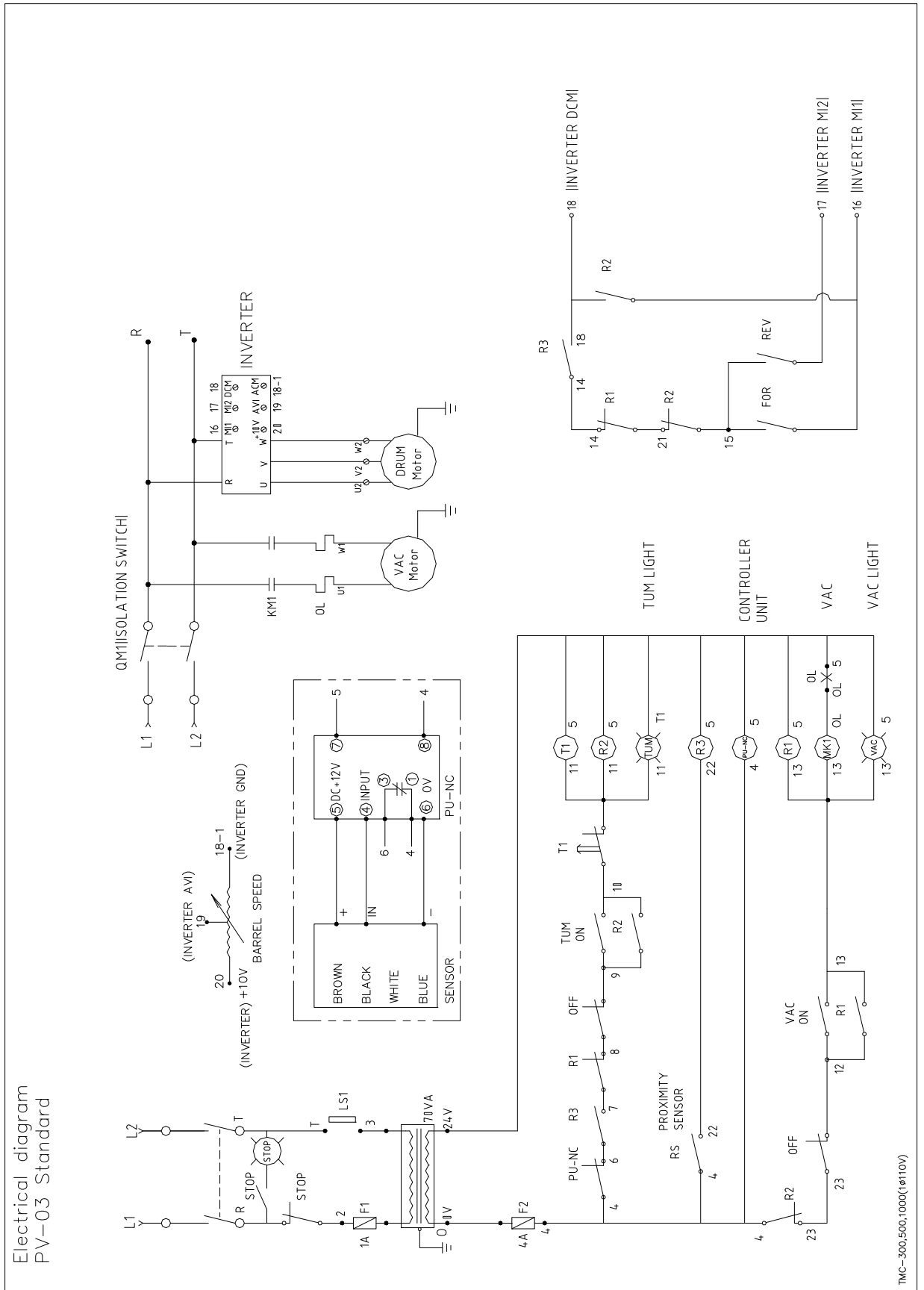

6.3 ELECTRICAL BOX (1 φ)

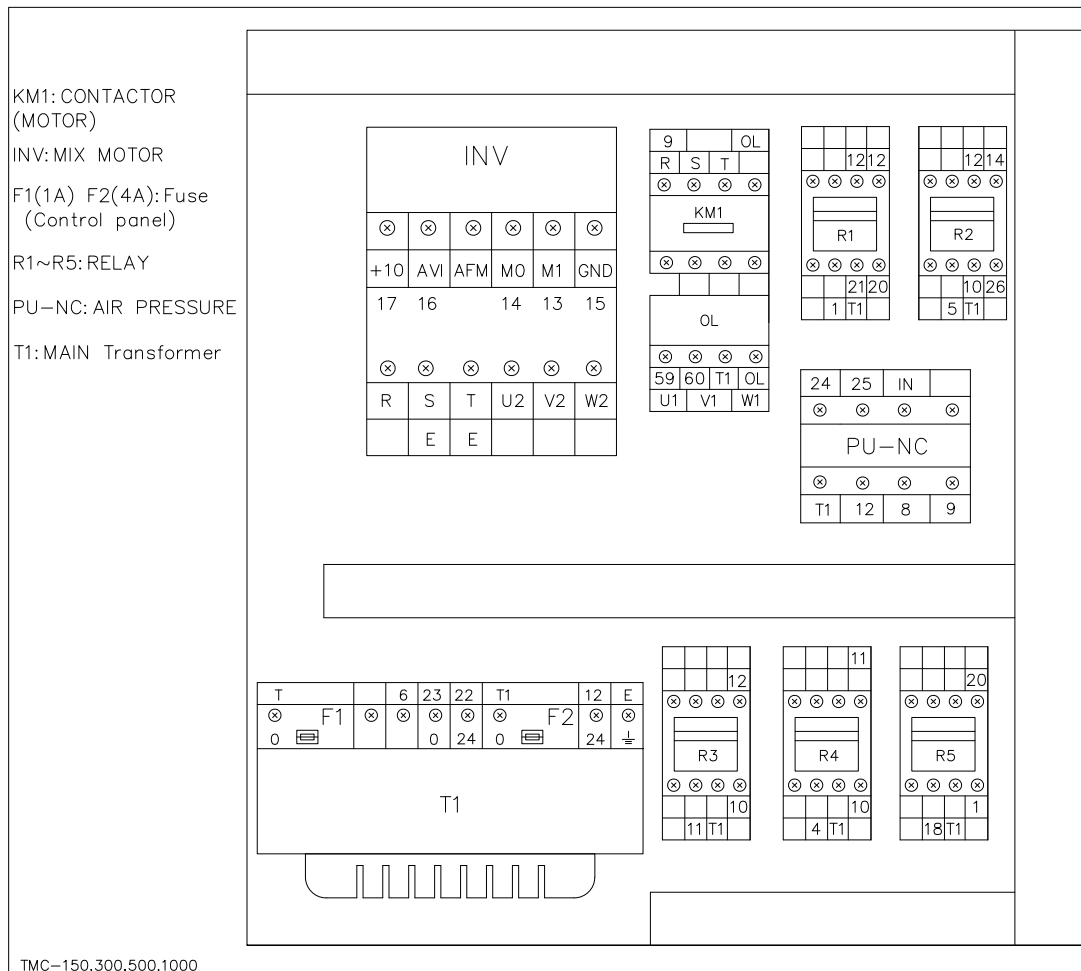

ITEM	PART NO.	DESCRIPTION	SPECIFICATION	Q'TY	NOTE
MS1	2810739	Contactora	CU-11-B5 (AC24V)	1	
MS2~3	2810758	Contactora	CU-18-4A	2	
TMR1.2.4.6	2832024	Time Relay	GE1A-B10HAD24	4	
TMR3.5	2833324	Time Relay	ANLY AMY-2 30S	2	
	2833329	Socket Relay	PYF08A-E MY2	2	
F1~F2	2890048	Fuse	20mm 1A	1	
R1~3	2830132	Relay	RU4S-C-A24	3	
	2831106	Socket Relay	SY4S-05D	3	
OL1~2	2811537	Relay, Overload	RHU-10K1(9-12.5A)	1	
	2811539	Relay, Overload	RHU-10K1(15-20A)	1	
T1	28960025	Transformer	120VA 110V/0-24V OF-24V UL	1	