



PromaxVac.

**Manufacturer of Food Processing
& Packaging Machinery**



QUALITY YOU CAN TRUST!

Head Office

1915 E. Acacia Street, Ontario, CA91761, USA
Tel:1-909-923-3888 Fax:1-909-923-3588
E-mail:sales@promarksvac.com

East Coast Office

JVR INDUSTRIES INC.
100 West Drullard Ave Lancaster NY14086, USA
Tel:1-716-897-4309 Fax:1-716-897-4731
www.jvrinc.com

Asia Office

Foodmax Machinery Co., Ltd.
No 9 Jhongsing Road, Chia-Tai Industrial Area, Chia-Yi, 61252, TAIWAN
TEL:886-5-2383788 FAX:886-5-2385388
E-mail:sales@foodmax.us

<http://www.promaxvac.com>

TM Series Vacuum Tumblers and Massagers

MODELS	TM-20	TM-40
Tumbler Capacity	22 lbs./ 10 kg	44 lbs./ 20 kg
Vacuum Capacity	2.4m3/h (dry pump)	2.4m3/h (dry pump)
Voltage	110V/1ph/60Hz 4.4A	110V/1ph/60Hz 4.4A
Machine Size WxLxH	520x635x490mm 21"x25"x19"	520x722x520mm 21"x28"x21"
Machine Weight	66 lbs.(30kg)	77 lbs.(35kg)

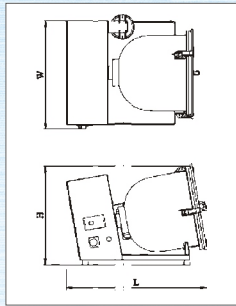

Promax Tumblers / Massagers:

TM-150/300/500/1000/1500/2000/3000/4000 are constructed with heavy duty stainless steel, Busch vacuum pumps with liquid trap, variable speed, continuous vacuum, and reverse discharge function. Great for marinated product, improved quality, increased productivity and higher profit margins.

MODELS	TM-150	TM-300	TM-500
Tumbler Capacity	154 lbs./ 70kg	308 lbs./ 140kg	660 lbs./ 300kg
Vacuum Capacity	20m3/h (0.9kw)	20m3/h (0.9kw)	20m3/h (0.9kw)
Voltage	110V/1ph/60Hz 19.54A	110V/1ph/60Hz 19.54A	110V/1ph/60Hz 19.54A
Machine Size WxLxH	1215x940x1380mm 48"x37"x54"	1350x940x1460mm 53"x37"x57.5"	1490x940x1660mm 59"x37"x65"
Dimension AxBxC	630xØ560x815mm 25"x Ø22"x32"	760xØ720x735mm 30"x Ø28"x29"	860xØ860x765mm 34"x Ø34"x30"
Machine Weight	622 lbs.(282kg)	661 lbs.(300kg)	794 lbs.(360kg)

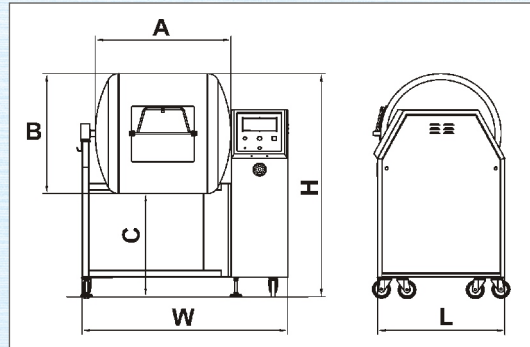

MODELS	TM-1000	TM-1500	TM-2000	TM-3000	TM-4000
Massager Capacity	1000lbs./454kg	1500lbs./680kg	2000lbs./900kg	3000 lbs./1360kg	4000 lbs./1814kg
Vacuum Capacity	40m3/h (2hp/2kw)	63m3/h (3hp/2.4kw)	100m3/h (5hp/4kw)	205m3/h (8hp/7.5kw)	205m3/h (8hp/7.5kw)
Voltage	220V/3ph/60Hz 14.8A	220V/3ph/60Hz 16.8A	220V/3ph/60Hz 27A	220V/3ph/60Hz 38A	220V/3ph/60Hz 38A
Machine Size WxLxH	2065x1730x1790mm 81"x68"x70"	2230x1880x1910mm 88"x74"x75"	1374x2264x1987mm 54"x89"x78"	1568x2473x2084mm 62"x97"x82"	1568x3131x2084mm 62"x123"x82"
Machine Weight	1616 lbs.(733kg)	1720lbs.(780kg)	2750 lbs.(1250kg)	3554 lbs.(1612kg)	3960 lbs.(1800kg)

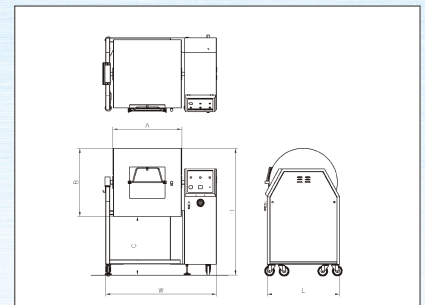

MODELS	TMC-150	TMC-300	TMC-500	TMC-1000
Tumbler Capacity	180lbs. / 80kg	330lbs. / 150kg	660lbs. / 300kg	1000lbs. / 460kg
Vacuum Capacity	20m3/h (0.9kw)	20m3/h (0.9kw)	20m3/h (0.9kw)	20m3/h (0.9kw)
Motor Horse Power	1Hp	1Hp	1Hp	1Hp
Voltage	110V/1ph/60Hz 19.54A	110V/1ph/60Hz 19.54A	110V/1ph/60Hz 19.54A	110V/1ph/60Hz 19.54A
Machine Size WxLxH	1207x940x1378mm 48"x37"x54"	1392x940x1520mm 55"x37"x60"	1392x940x1610mm 55"x37"x63"	1890x940x1610mm 74"x37"x63"
Dimension AxBxC	625x545x1708mm 25"x Ø21"x67"	860x670x850mm 34"x Ø26"x33"	860x860x765mm 34"x Ø34"x30"	1360x860x765mm 54"x Ø34"x30"
Machine Weight	622 lbs./282kg	661 lbs./300kg	794 lbs./360kg	1168 lbs./530kg

Options:

- Single phase motor available up to 100m3/h (5hp) pump
- Pump size • Voltage • Custom sizes are available
- Large massager available upon request TM-5000 and above
- Buggy (200L, 300L) • Buggy dumper • Suction tank



TM-20
TM-40

TM-150
TM-300
TM-500

TM-1000 TM-1500 TM-4000
TM-2000 TM-3000 TM-5000

All specifications are subject to change without notice.

Ask Us about our quality products !