

# TC Series Vacuum Chamber Packaging Machines

## Technical Specifications



**TC-280 F**

MODELS	TC-280-C
Chamber Size (F) (H)	14.2"/360mm 15.2"/385mm
Chamber Depth (E+I)	5.7"/145mm
Distance Between Seal Bars (B)	11.1"/282mm
Seal Bar Length (A)	11.8"/300mm
Vacuum Pump Capacity	6m3/h (0.25Kw)
Voltage	110V/1ph/50/Hz/15A
Machine Size C x G x D	370x459x460mm 15"x18"x18"
Machine Weight	117 lbs.(52kg)

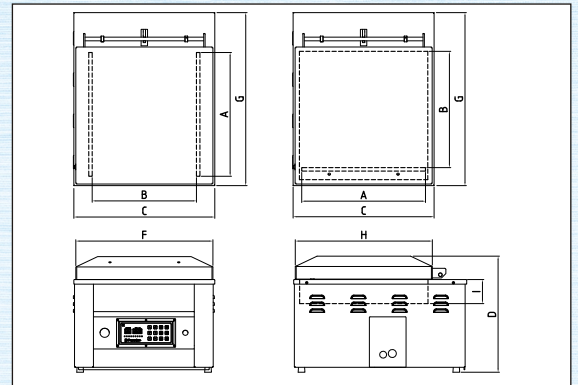

**TC-420 LR**

MODELS	TC-420 P1(F)	TC-420 P2(LR)	TC-420F	TC-420LR	TC-520F	TC-520LR
Chamber Size (F) (H)	19.9"/505mm 19.3"/490mm	19.9"/505mm 19.3"/490mm	19.9"/505mm 19.3"/490mm	19.9"/505mm 19.3"/490mm	23.6"/600mm 23.6"/600mm	23.6"/600mm 23.6"/600mm
Chamber Depth (E+I)	9.1"/230mm	9.1"/230mm	9.1"/230mm	9.1"/230mm	7.9"/200mm	7.9"/200mm
Distance Between Seal Bars (B)	15"/380mm	14.6"/370mm	15"/380mm	14.6"/370mm	19.3"/505mm	16.5"/420mm
Seal Bar Length (A)	17.7"/450mm	16.9"/430mm	17.7"/450mm	16.9"/430mm	21.3"/540mm	21.3"/540mm
Vacuum Pump Capacity	20m3/h (0.75Kw)	20m3/h (0.75Kw)	21m3/h (0.75Kw)	21m3/h (0.75Kw)	21m3/h (0.75Kw)	21m3/h (0.75Kw)
Voltage	110V/1ph/ 50Hz/15A	110V/1ph/ 50Hz/15A	110V/1ph/ 50Hz/15A	110V/1ph/ 50Hz/15A	110V/1ph/ 50Hz/15A	110V/1ph/ 50Hz/15A
Machine Size C x G x D	520x550x535mm 20"x22"x21"	520x550x535mm 20"x22"x21"	520x550x535mm 20"x22"x21"	520x550x535mm 20"x22"x21"	615x755x510mm 24"x30"x20"	615x755x510mm 24"x30"x20"
Machine Weight	119 lbs.(54kg)	119 lbs.(54kg)	119 lbs.(54kg)	119 lbs.(54kg)	280 lbs.(127kg)	280 lbs.(127kg)



**TC-520 LR**

**Standard Features:**

- PD-01 Digital control panel
- Stainless steel construction
- Clear see through lid
- Bladder activated sealing
- BUSCH vacuum pump (exclude TC-280, TC-420 P1, TC-420 P2)
- Air regulator (TC-520)
- 6mm seal wire or electric cut-off seal bar on TC-420, TC-520
- 6mm seal wire or electric cut-off on TC-280
- Dome lid on TC-280, TC-420

**Options:**

- PNC-01 Computerized water resistant control panel (IP 56) (14 programs with oil indicator)
- Voltage
- Gas flush
- Soft air
- Stainless steel cart
- Chamber sizes available

• Note: "P" Machines have a Promax Brand Vacuum Pump

**All specifications are subject to change without notice.**



**TC-350 FLR**

MODELS	TC-350FLR
Chamber Size (C) (A1)	41.3"/1050mm 16.7"/425mm
Chamber Depth (I)	4.7"/120mm
Seal Bar Length (A) (A1)	32.9x1/835mm 14.2"x2/360mm
Vacuum Pump Capacity	21m3/h (0.75kw)
Voltage	110V/1ph/60Hz/15A
Machine Size C x G x D	1066x485x430mm 42"x19"x17"
Machine Weight	254 lbs.(115kg)

**TC350 Standard Features:**

- PD-01 Digital control panel
- Stainless steel construction
- Clear see through lid
- Filler Plates
- Air assist regulator
- 6mm seal wire
- Seal bar selector (front/sides/all)

**Options:**

- PNC-01 Computerized water resistant control panel (IP 56) (14 programs with oil indicator)
- Voltage
- Gas flush
- Floor stand
- Vacuum sensor
- Electric cut off seal bars
- Custom chamber sizes available

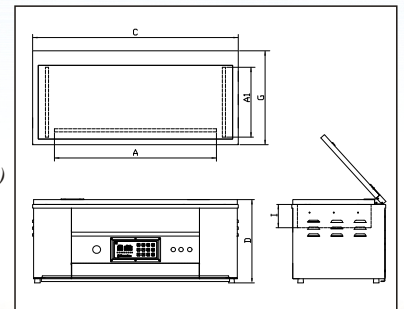

**All specifications are subject to change without notice.**