

SC Series Vacuum Chamber Packaging Machines

Technical Specifications

MODELS	SC-420LR	SC-520LR
Chamber Size (F) (H)	19.9"/505mm 19.3"/490mm	23.6"/600mm 23.6"/600mm
Chamber Height (E+I)	7.1"/230mm	7.9"/200mm
Distance Between Seal Bars (B)	14.6"/370mm	17.7"/450mm
Seal Bar Length (A)	16.9"/430mm	21.3"/540mm
Vacuum Pump Capacity	21m3/h (0.75Kw)	21m3/h (0.75Kw)
Voltage	110V/1ph/50Hz/15A	110V/1ph/50Hz/215A
Machine Size C x G x D	520x490x914mm 21"x19"x36"	610x756x916mm 24"x30"x36"
Machine Weight	234 lbs.(106kg)	309 lbs.(140kg)

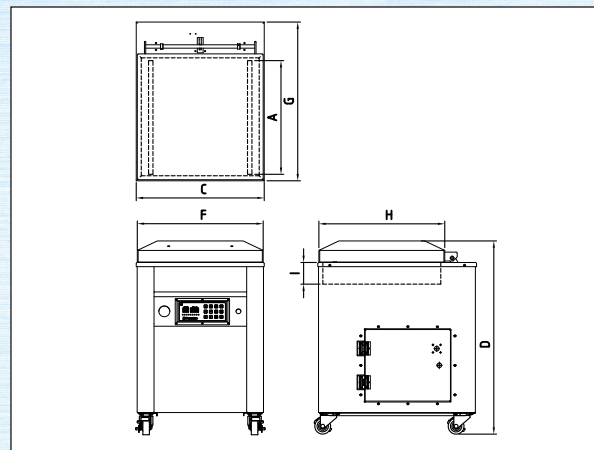

MODELS	SC-680LR	SC-800-LR
Chamber Size (F) (H)	33.9"/860mm 26.6"/660mm	36.2"/920mm 29.1"/740mm
Chamber Height (E+I)	7.1"/180mm	10"/255mm
Distance Between Seal Bars (B)	26.2"/665mm	28.5"/725mm
Seal Bar Length (A)	20.5"/520mm	26"/660mm
Vacuum Pump Capacity	40m3/h (1.5Kw)	63m3/h (1.8Kw)
Voltage	220V/3ph/50Hz/14.9A	220V/3ph/50Hz/18.7A
Machine Size CxGxD	900x665x1000mm 35"x26"x39"	960x805x1075mm 38"x32"x42"
Machine Weight	432 lbs.(196kg)	600 lbs.(272kg)

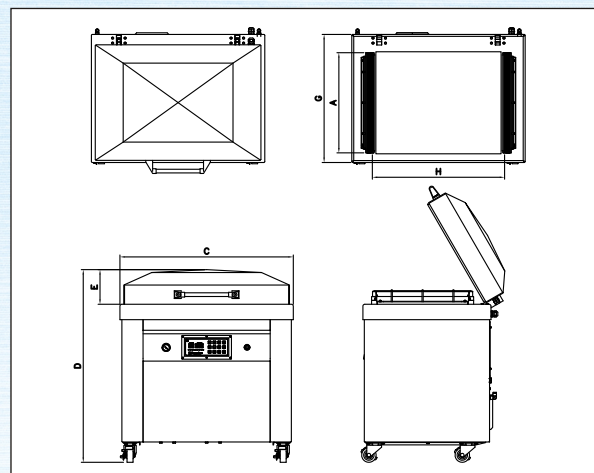

SC-680 / 800 LR

Standard Features:

- Flat chamber for easy cleaning (SC-680LR and SC-800LR)
- **PD-01** Digital control panel
- Bladder activated sealing
- Durable removable aluminum cushion bar
- BUSCH vacuum pump
- Air assist regulator
- 6mm seal wire or cut-off

Options:

- **PNC-01** Computerized water resistant control panel (IP 56)
(14 programs with oil indicator)
- Single phase motor available (up to 100m3/h, 5hp)
- Pump size
- Voltage
- Gas flush
- Top & bottom seal
- Mechanical knife cut-off system (SC-680/800)
- Custom chamber sizes available
- SC680, SC800 lid height (10" or 12" option)

All specifications are subject to change without notice.