



MSK-98

Brine Injector Operation Manual

Operation Manual

Version 6.9.1

1915 E. Acacia Street, Ontario, CA91761, U.S.A

TEL : 1-909-923-3888

FAX : 1-909-923-3588

<http://www.promarksvac.com>

S/N:

QC SIGNATURE:

INDEX

INTRODUCTION	1
1. TECHNICAL PARAMETER	2
2. INSTALLATION	3
3. ITEMS TO CHECK BEFORE START UP	3
4. CLEANING	4
4.1 CLEANING THE BRINE PIPE	4
4.2 CLEANING THE HOUSING	4
4.3 NEEDLE CLEANING PROCEDURE	4
5. MAINTENANCE	5
5.1 DAILY VISUAL INSPECTION	5
5.2 CLEANING	5
5.3 BRINE CONSIDERATIONS	5
5.4 BRINE FILTERS	5
5.5 THE REDUCER	5
6. TROUBLESHOOTING	6
7. OPERATING PARAMETERS	8
8. ELECTRIC DIAGRAM AND INTRODUCTION	28
9. FABRICATION	31
9.1 BESE MACHINE	32
9.2 LINK MECHANISM	39
9.3 RECIPROCATION MECHANISM	42
9.4 INJECTION MECHANISM	45
9.5 SUPPLY TRUCK	49
9.6 OPERATOR BOX	52
9.7 ELECTRICAL BOX	54
10. PACKING LIST	56
11. NEEDLE CLEANING PROCEDURE	57

MSK-98 Brine Injector Introduction

The Promax MSK-98 brine injector has been designed and manufactured utilizing advanced technology and electronics. It has been designed to promote ease of operation and reliable performance. The machine incorporates a complete safety system for the protection of the operator.

The step feed system on the MSK-98 uses a hydraulic motor drive for unsurpassed accuracy. The three piece removable feed shoe facilitates ease of cleaning. The machine utilizes an advanced air head design that produces a perfect injection effect for both bone in and boneless products.

The injection frequency, injection pressure, injection rate as well as the step spacing is all adjustable to meet your specific requirements.

The MSK-98 is equipped with a three stage filtration system that prevents scrap from clogging the needles and causing jamming. The brine tank is equipped with an agitator to help prevent the holes in the filter from becoming clogged and the unique pneumatic needle cleaning helps speed up the needle cleaning process.

1. Technical parameter

First injecting rate : ≥ 140

Second injecting rate : ≥ 180

Injecting speed : 15-56 times/min

Power : 220V 60Hz

Pressure : 0.2-0.5Mpa

Needle quantity : 98

Specification : MSK-98

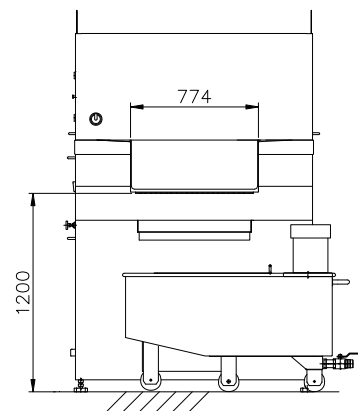
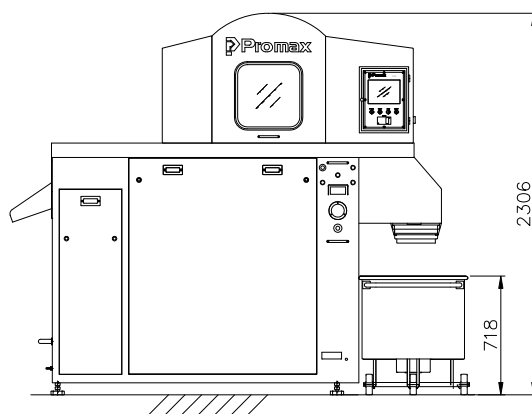
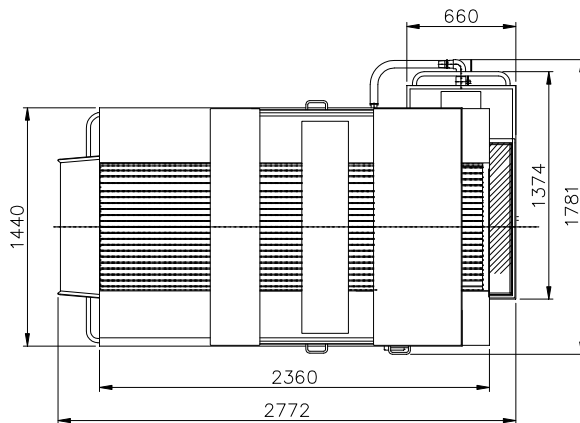

2. Installation

2.1 **Placing and Leveling the Machine:** There are four wheels and four spiral anchors on the bottom of the machine. When moving the machine, screw in the anchors and the four wheels can carry the machine. Once the machine is in the designated site, screw out the anchors counter clockwise, then the four wheels will lift off the ground and adjust the anchors to level the fuselage.

2.2 **Compressed Air Connection:** There is a compressed air hose union on the left bottom of the machine's back which can be used for this connection.

2.3 **Main Power Connection:** The MSK-98 comes with a power cord attached. The electrical requirements can be found on the machine's serial number plate located at the rear of the machine. Promax recommends that the main power connection be installed by a certified electrician who is familiar with your local building codes

2.4 **Brine Preparation:** Make sure the brine does not contain granules or long fibers and does not contain ingredients that will erode stainless steel or Teflon. Check to make sure that the quick change couplers on the hose that connects the brine tank to the injector are firmly fastened and that the level of brine in the tank is higher than the inlet of the brine pump.

3. Items to Check Before Start Up

3.1 The four doors and the top-hoods must be closed otherwise the machine cannot be run. The PLC control system will indicate whether all the doors are closed and the safety interlocks engaged.

3.2 Check the level of the brine in the brine tank. It must be above the height of the brine pump inlet. Caution: To run the pump with the brine level too low can cause the pump to fail.

3.3 Check to make sure that the brine in the tank is clean and free of any foreign debris.

4. Cleaning

4.1 **Cleaning the Brine Pipe:** Once the injection process has been completed another complete cycle should be run using clean water. This will remove any sediment or residue from the brine system.

4.2 **Cleaning the Housing:** Withdraw the lace bar first, then take out the gear frame and wash out the water channel.

4.3 Needle Cleaning Procedure

4.3.1 Needle head removal

- a. Release air pressure from the needle head air valve.
- b. When the injecting station is at location bottom.
- c. turn off the “needle air”
- d. Pull out the 4 pin sets from injecting station (2 pin sets at front side + 2 pin sets at rear side).
- e. Turn on the “needle head”, its lamps will lighten up, then the injection station goes up.
- f. Move the injecting station to left, and then change the needles.
- g. After finishing change the needles, move the injecting station back to right.
- h. Check the 2 sensors (one of each front and back), if the injecting station back to the correct location the sensors will lighten up.
- i. Turn off the “needle head”, the injecting station goes down.
- j. Put in 4 pin sets back to injecting station.
- k. Turn on the “needle air”
- l. Solve out any fault status showing on the display, then the machine can work again.

4.3.2 Needle removal

- a. Pull upward on needles to remove them.

4.3.3 Needle cleaning

- a. Insert needle into needle cleaner.
- b. Press needle cleaner button (on control board). Air will remove material

from needle.

4.3.4 Needle replacement

- a. Lightly lubricate the needle with food grade grease. This grease may be ordered from your dealer (reference part # 0123456) Important note: This grease was specifically chosen for proper operation of the injector head. The warranty on the injector head depends on the proper use and application of this grease.
- b. Re-insert the needle into the head and lower scraper block. Make sure the needle is flush with the head.
- c. After all the needles are installed remove any excess grease. However make sure the heads of the needles are lightly greased.

4.3.5 Needle Head Replacement

- a. Return the needle head carefully to the original position.
- b. Return ring push pins to the locking position.
- c. Lift air valve to return the air pressure to the needle head.

5. Maintenance

5.1 Daily Visual Inspection: The machine should be subject to a through visual inspection to determine if any parts are showing undue wear or damage. Repair or replace any such part before start up. If the machine has just been brought out of storage it should be completely lubricated before use.

5.2 Cleaning: The machine should be washed at the end of each shift and all key operating parts should be oiled to prevent excess wear because of the wet environment.

5.3 Brine Considerations: To ensure that the brine is clean do not use any insoluble ingredients, such as long fibers, minced meat or hard particles. To

use such ingredients can easily cause jamming of the needles and the brine pump.

5.4 **Brine Filters:** Keep the two stage brine filter screens clean at all times and replace or repair them if they become worn.

5.5 **The Reducer:** The reducer must be oiled after the first 100 hours of use and then regularly every 2500 hours of use. Promax recommends the following lubricants: N220-320 for ambient.

6. Troubleshooting

Problem	Reason analysis	Solution
No water comes out from the needle tube	Brine pump jam Needle tube jam Brine pump motor trouble	Clean up obstruction on the brine pump Blow out obstructions in the needles or change needles Motor's wire error, brine pump's
Water yield is not enough	Brine pump or needle tube jams Pressure is too low	Clean up obstructions Change spillway discharge
Noise from pressure regulating valve	Pressure is in the range of jolting	Change the pressure out from the range of jolting
Brine chamber leaking	There is cleft in the needle tube The joint ring in the brine chamber is damaged	Change needle Replace with new joint ring

air chamber leaking	The joint ring in the air chamber is damaged	Replace with new joint ring
---------------------	--	-----------------------------

7. Operating Parameters

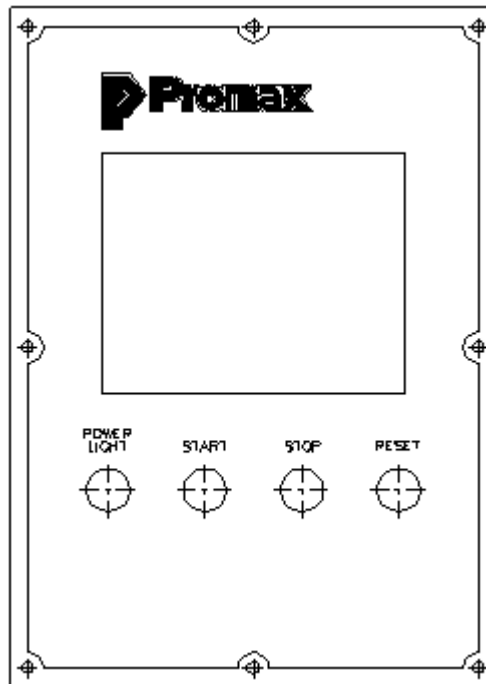

PROMAX INC. U.S.A.

1915 E. Acacia Street
Ontario, CA91761, U.S.A

TEL : (909) 923-3888

Fax : (909) 923-3588

[http : //www.promarksvac.com](http://www.promarksvac.com)

When power is on, please check the display on the touch screen if there is any phase error showing. Once there is a phase error, please check the phase rotation.

1. At the Promax start up page, touch anywhere of screen to go into operation page.

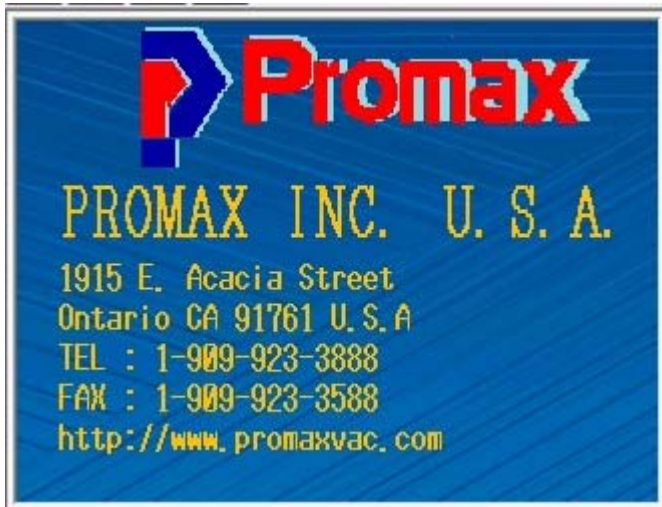

(PROMAX START UP PAGE)

2. Main operation page:
 1. Auto mode
 2. Manual mode
 3. Injecting head change
 4. Belt wash
 5. Fault history
 6. Data input
 7. Signal input
 8. Signal output



(MAIN OPERATION PAGE)

Note:

{1.} Once the “STOP” light is on with any failure messages showing on the bottom screen, please fix it accordingly then press the “RESET” (YELLOW BOTTOM) to dissolve the safety protect lock.

3. Setting up the “DATA INPUT” before machine starting injecting.

(1) 、 Press the “DATA INPUT” icon  to go to “DATA INPUT” page.



(2) 、 Enter “PARAMETER” 1-30, total 30 sets/programs can be used and chosen.



(3) 、 Enter “PRODUCT” name 

(4) 、 Enter “BELT WALKING DISTANCE” (Min 1- Max 500)



Index distance per cycle:

Basic parameter is 15mm per unit.

Minimum setting parameter is “1”, Maximum setting parameter is “500”.

Ex: If the setting parameter is “2”, so $2 \times 15\text{mm} = 30\text{mm}$

30mm will be the index distance per cycle.

(5) 、 Enter “INJECTING TIME SETTING”

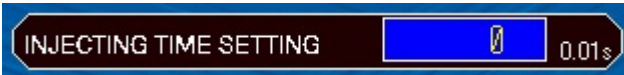

Basic parameter is 0.01s per unit.

Ex: If the setting parameter is “35”, so $35 \times 0.01\text{s} = 0.35$ second

0.35s will be the needle injecting time.

(6) 、 Enter “INJECTING POSITION SETTING” (Min 65- Max 280)



(65-280mm)

Minimum setting is 65mm, Maximum setting is 280mm.

Ex: If the “INJECTING POSITION SETTING” is 70mm, 70mm will be the distance from Belt to the needle injecting location.

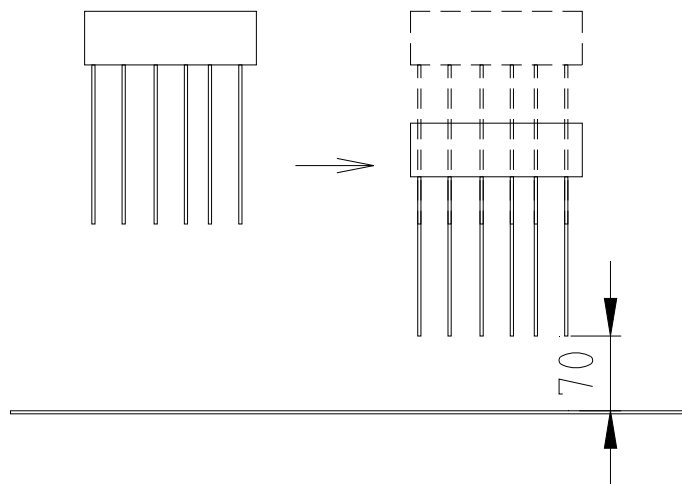

(7) 、 Press “NEXT” icon  to go into “DATA INPUT” page 2.

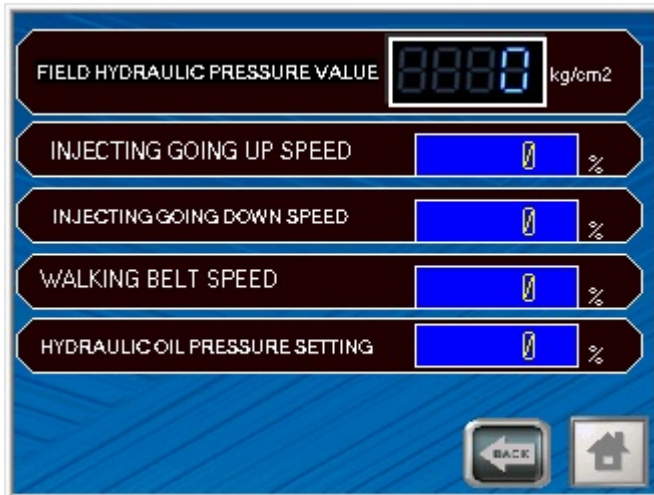

(DATA INPUT PAGE 2)

(8) 、 Enter “INJECTING GOING UP SPEED” (Min 40- Max 100)



(9) 、 Enter “INJECTING GOING DOWN SPEED” (Min 40- Max 100)



(10) 、 Enter “WALKING BELT SPEED” (Min 30- Max 62)



(11) 、 Enter “HYDRAULIC OIL PRESSURE SETTING” (Min 10-Max 100)



Note: When Hydraulic oil pressure is getting strong, the **1. Injecting speed**, and **2. Belt walking speed** are getting faster.

(12) 、 Press “BACK” icon  to back to last page.

(13) 、 Press “HOME” icon  to back to “Main operation page”.

4. Manual mode:



(1) 、 Press the “MANUAL” icon to go into “MANUAL OPERATION PAGE”



(MAIN OPERATION PAGE)

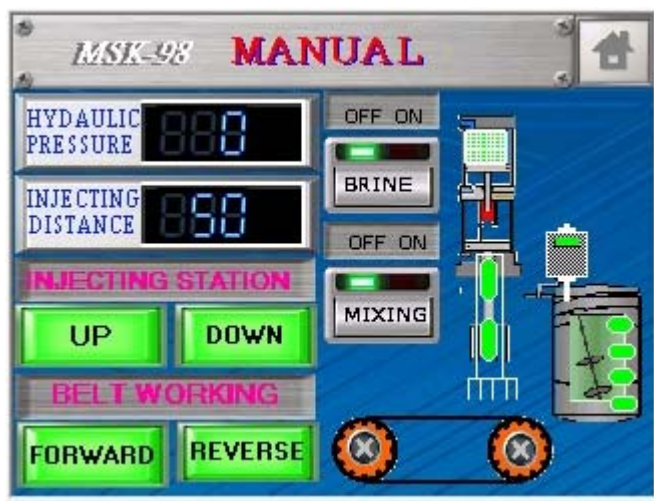

(MANUAL OPERATION PAGE)

(2) 、 Injecting station “UP” icon 

(3) 、 Injecting station “DOWN” icon  ◦

(4) 、 Belt working “FORWARD” icon  ◦

(5) 、 Belt working “REVERSE” icon  ◦

(6) 、 Brine pump switch: press the “BRINE” icon



for ON/OFF.

(7) 、 Mixing motor switch: press the “MIXING” icon



for ON/OFF.

(8) 、 Hydraulic pressure (kg/cm²)



(9) 、 Injecting distance (mm)



(distance between belt to the needle injecting localtion)

Note:

The “BELT” doesn’t work



once the “INJECTING DISTANCE” is under “60mm”

5. Auto mode:

(1) 、 Press the “AUTO” icon

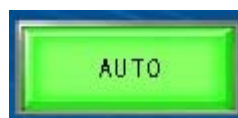

to go into “AUTO OPERATION PAGE”.



(MAIN OPERATION PAGE)



(AUTO OPERATION PAGE)

(2) 、 Make all the settings before pressing “START” bottom (green bottom) when the machine is working under “AUTO MODE”.



(Press the “DATA INPUT” icon at “MAIN OPERATION PAGE”, and make all the settings, ex. “INJECTING POSITION SETTING”, “INJECTING GOINH UP/DOWN SPEED”, “WALKING BELT SPEED”, “HYDRAULIC PRESSURE SETTING”.)

(3) 、 Auto mode running with 2 monitored data blank to be showed:



1 、 Hydraulic pressure (kg/cm²)



2 、 Injecting distance (mm)

(distance between belt to the needle injecting localtion)

(4) 、 Press the “STOP BOTTOM”(red bottom) for stop machine running while “AUTO MODE”.

7、Belt washing:



- (1)、Press the “BELT WASH” icon at “MAIN OPERATION PAGE” to go into data page of “BELT WASH”.

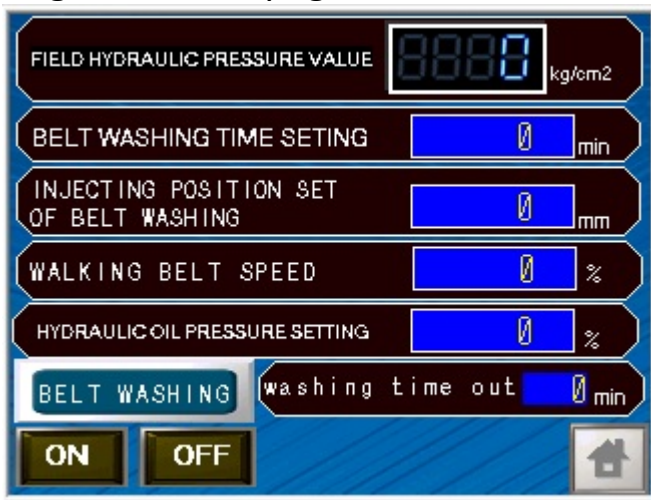

(DATA PAGE OF BELT WASH)

- (2)、Enter “BELT WASHING TIME SETING” (Min 2- Max 500)



2-500 MINUTE

- (3)、Enter “INJECTING POSITION SET OF BELT WASHING” (Min 70-Max 275)



70-275mm

- (4)、Enter “WALKING BELT SPEED” (Min 30-Max 55)



30%-55%

- (5)、Enter “HYRAULICOIL PRESSURE SETING” (Min 10-Max 100)

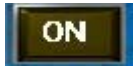

10-100%

- (6)、Once finished all the above settings, please press “on” icon  for starting belt washing.

(7) 、 After successfully starting belt washing:

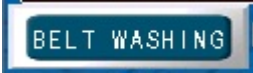
1 、 The “BELT WASHING” icon  will be blinking with red light.

2 、 Belt washing time countdown icon 

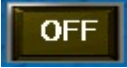
(8) 、 Press the “OFF” icon  to stop belt washing when the washing time is not completed.

8 、 Injecting change(needle change):

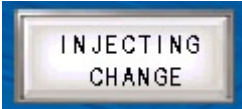
(1) 、 Press the “INJECTING CHANGE” icon  when machine is not running.

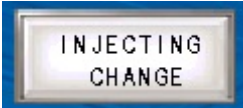
Once the “INJECTING CHANGE” icon  is blinking with red light, the needle will be going down to the end. Change or replace the needle when needle going down to the end.

(2) 、 Press the “INJECTING CHANGE” icon  again once finished needle change.

9、Signal input/output PLC:

(1)、Press the “HOME” icon  to back to “MAIN OPERATION PAGE” if not at “MAIN OPERATION PAGE”.



(MAIN OPERATION PAGE)

(2)、Press the “SIGNAL INPUT” icon  to view the PLC signal input data.



(SIGNAL INPUT -1)



(SIGNAL INPUT-2)



(SIGNAL INPUT -3)



(SIGNAL INPUT -4)

Note: The icons will be on with red light when the signals input PLC.



(3) Press the “SIGNAL OUTPUT” icon to view the PLC output signal data.



(SIGNAL OUTPUT -1)



(SIGNAL OUTPUT -2)

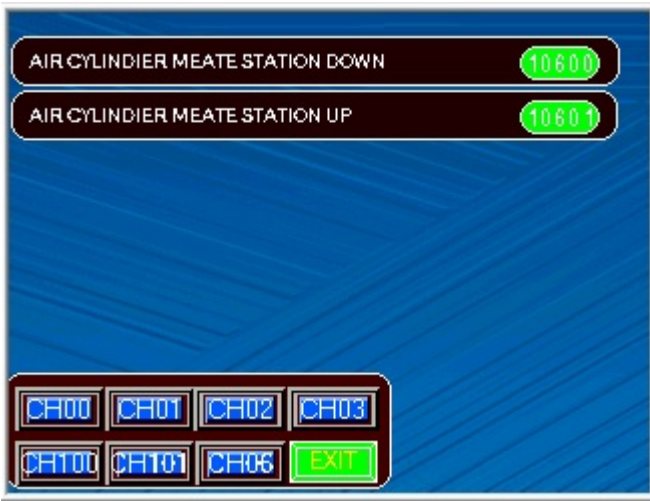

(SIGNAL OUTPUT -3)

Note: The icons will be on with red light when the PLC output the signals.

10、Fault history:

Press the “FAULT HISTORY” icon  to check fault record.

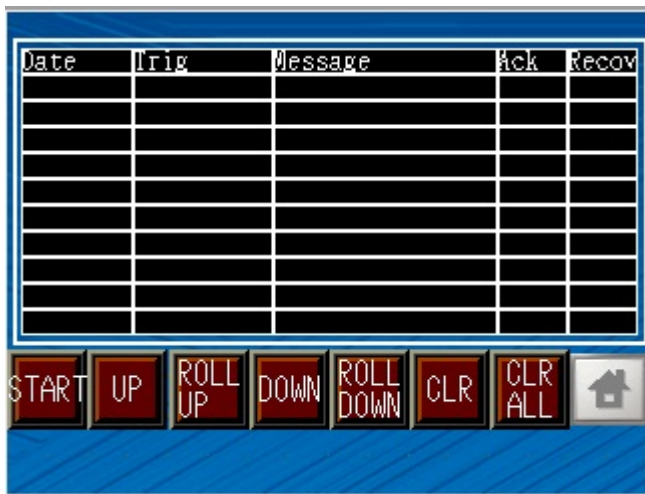

(FAULT HISTORY)

11 、 Fault / Failure messages:

(1) 、 If the machine does not work with any failure message showing on the bottom of screen, please fix it accordingly then press the “RESET” bottom(yellow bottom) to dissolve the safety protect lock to enable the machine running.

(2) 、 Failure messages list:

1. RECTILINEAR DISPLACEMENT TRANSDUCER FAILURE
2. WALKING BELT RELEASED
3. PRESSURE GAUGE FAILURE
4. HYDRAULIC FAN FUSE FAILURE
5. POWER PHASE FAILURE
6. EMERGENCY STOP
7. STOP
8. RIGHT FRONT SAFETY DOOR OPENED
9. INJECTING MOVE ABNORMAL
10. FRONT SAFETY DOOR SENSOR
11. ELECTRIC BOX FRONT SAFETY DOOR OPENED
12. REAL SAFETY DOOR OPENED
13. ELECTRIC REAL SAFETY DOOR OPENED
14. FRONT UPPER SAFETY DOOR OPENED
15. REAR UPPER SAFETY DOOR OPENED
16. RIGHT FRONT SAFETY DOOR OPENED
17. RIGHT REAR SAFETY DOOR OPENED
18. BRINE MOTOR OVERLOAD
19. HYDRAULIC MOTOR OVERLOAD
20. MIXING MOTOR OVERLOAD
21. Hydraulic rotary cylinder count abnormal
22. FRONT MIDDLE RIGHT DOOR OPENED
23. REAR MIDDLE LEFT DOOR OPENED
24. INJECTING STATION OUT OF UP LIMIT
25. INJECTING STATION OUT OF DOWN LIMIT

Note:

1、When the failure messages happened with “INJECTING STATION OUT OF UP LIMIT” or “INJECTING STATION OUT OF DOWN LIMIT”, please back to “MAIN

OPERATION PAGE” and press the “DATA INPUT” icon  to go into “DATA INPUT” page.



(DATA INPUT PAGE)

2、Press the “SAFETY BY PASS” icon



and enter the password “1234” at the first time enter.



(SAFETY BY PASS- ENTER PASSWORD PAGE)



(SAFETY BY PASS PAGE)

3、 If the failure message is “INJECTING STATION OUT OF UP LIMIT”, please press

the “LIMIT SENSOR OF TOP PROTECT ON” icon  to dissolve the safety proect lock, the icon “LIMIT SENSOR OF TOP PROTECT ON” will become “LIMIT SENSOR OF TOP PROTECT OFF” with blinking red lights, and press the  back to “MAIN OPERATION PAGE”, press the “RESET” bottom(yellow bottom) to dismiss the failure message to allow the machine working again.

4、 Once the failure message happened again with “INJECTING STATION OUT OF UP LIMIT” :

(1)、 Lower down the parameter “INJECTING POSITION SETTING”, “INJECTING GOING UP/DOWN SPEED” and “HYDRAULIC OIL PRESSURE SETTING”.

(2)、 It is normal if injecting station out of up limit happened once or twice during running, if it keeps happening often after adjusting parameter, please contact the official technician and request a formal inspection.

5、If the failure message is “INJECTING STATION OUT OF DOWN LIMIT”, please

press the “LIMIT SENSOR OF DOWN PROTECT ON” icon  to dissolve the safety protect lock, the icon “LIMIT SENSOR OF DOWN PROTECT ON” will become “LIMIT SENSOR OF DOWN PROTECT OFF” with blinking red

lights, and press the  back to “MAIN OPERATION PAGE”, press the “RESET” bottom(yellow bottom) to dismiss the failure message to allow the machine working again.

6、Once the failure message happened again with “INJECTING STATION OUT OF DOWN LIMIT” :

(1)、Lower down the parameter “INJECTING POSITION SETTING”, “INJECTING GOING UP/DOWN SPEED” and “HYDRAULIC OIL PRESSURE SETTING”.

(2)、It is normal if injecting station out of down limit happened once or twice during running, if it keeps happening often after adjusting parameter, please contact the official technician and request a formal inspection.

7、If the machine door is required to open for inspection, please compulsorily dissolve the safety protect lock (SAFETY BY PASS).

Step of “compulsorily dissolve the safety protect lock”:

(1) Press the “DATA INPUT” icon  at the main operation page.



(DATA INPUT PAGE)

(2) Press "SAFETY BY PASS" for the first time enter.



, enter the password "1234"



(SAFETY BY PASS- PASSWORD PAGE)

(3) Press "DOOR SAFETY ON"



to unlock the door safety lock, the "DOOR SAFETY ON" becomes "DOOR SAFETY OFF".

When the machine is working under "DOOR SAFETY OFF", the machine will keep working without safety protect lock no matter if any door is opened. (Normally machine should work under "DOOR SAFETY ON", meaning machine will not work when one of any door is opened.)

(If successfully unlock the door safety protect lock, the blank of DOOR SAFETY OFF will be blinking with red light.)



(SAFETY BY PASS PAGE)

8. Electric diagram and introduction

Output wiring diagram

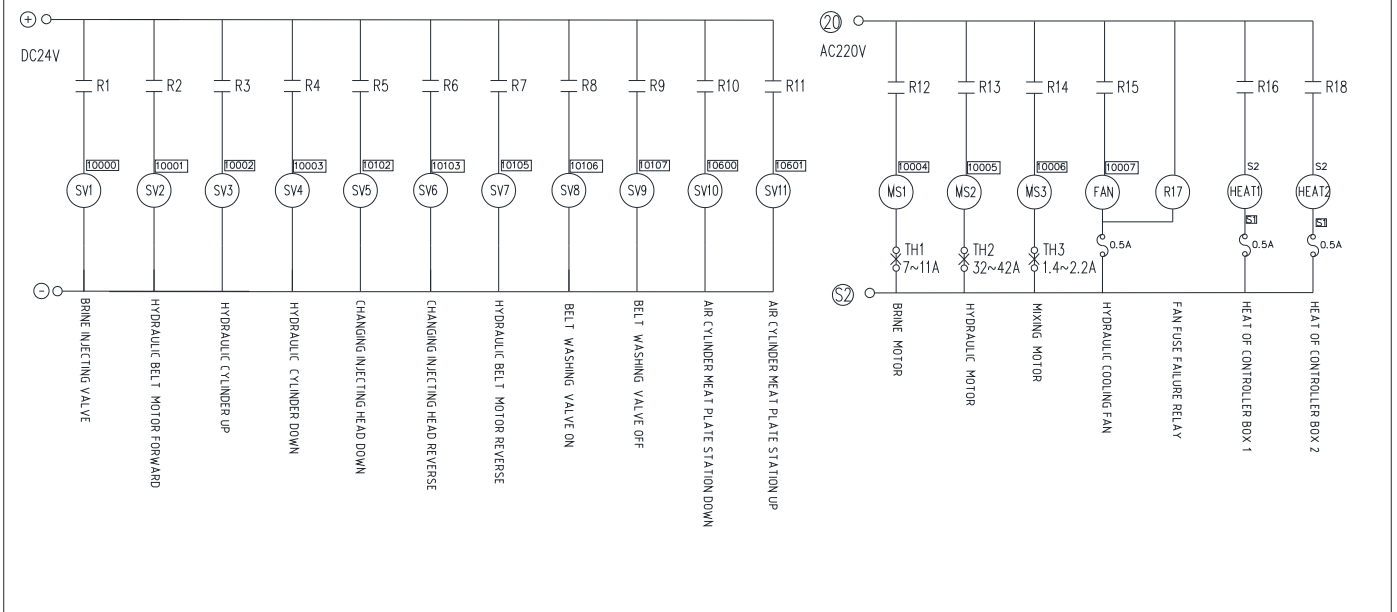

8. Electric diagram and introduction

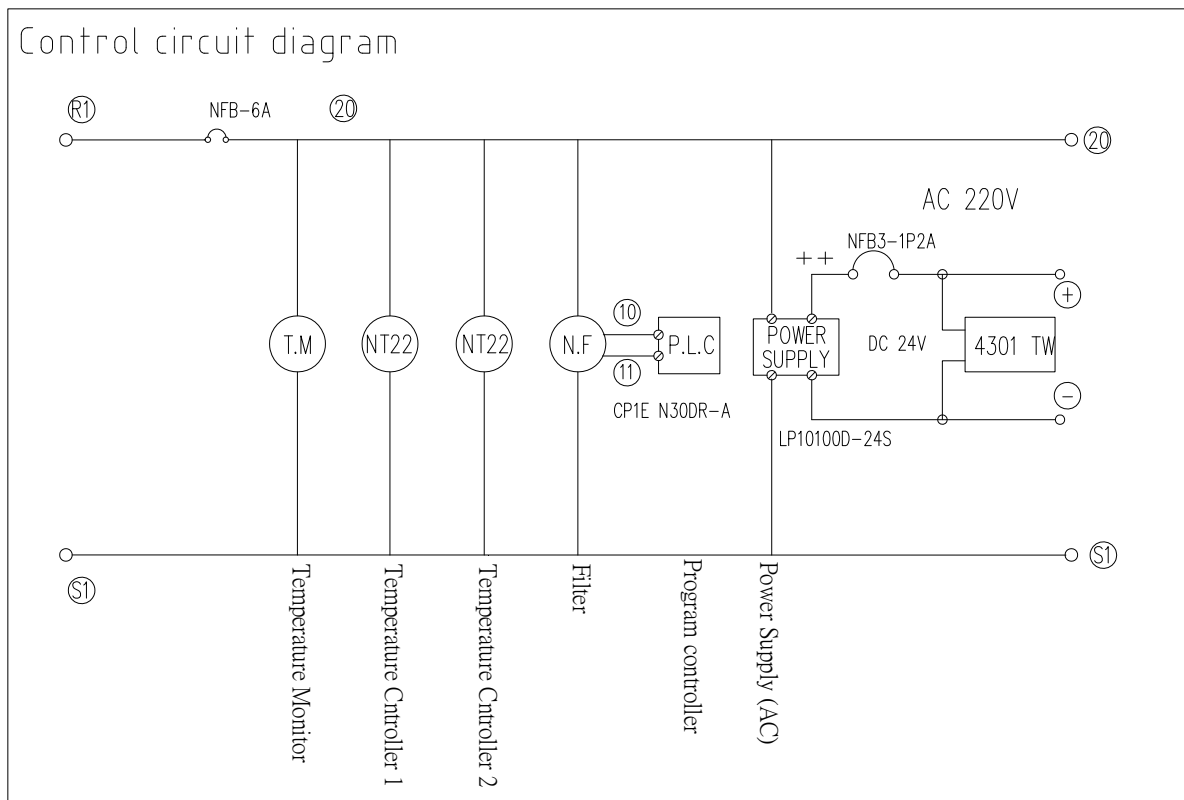
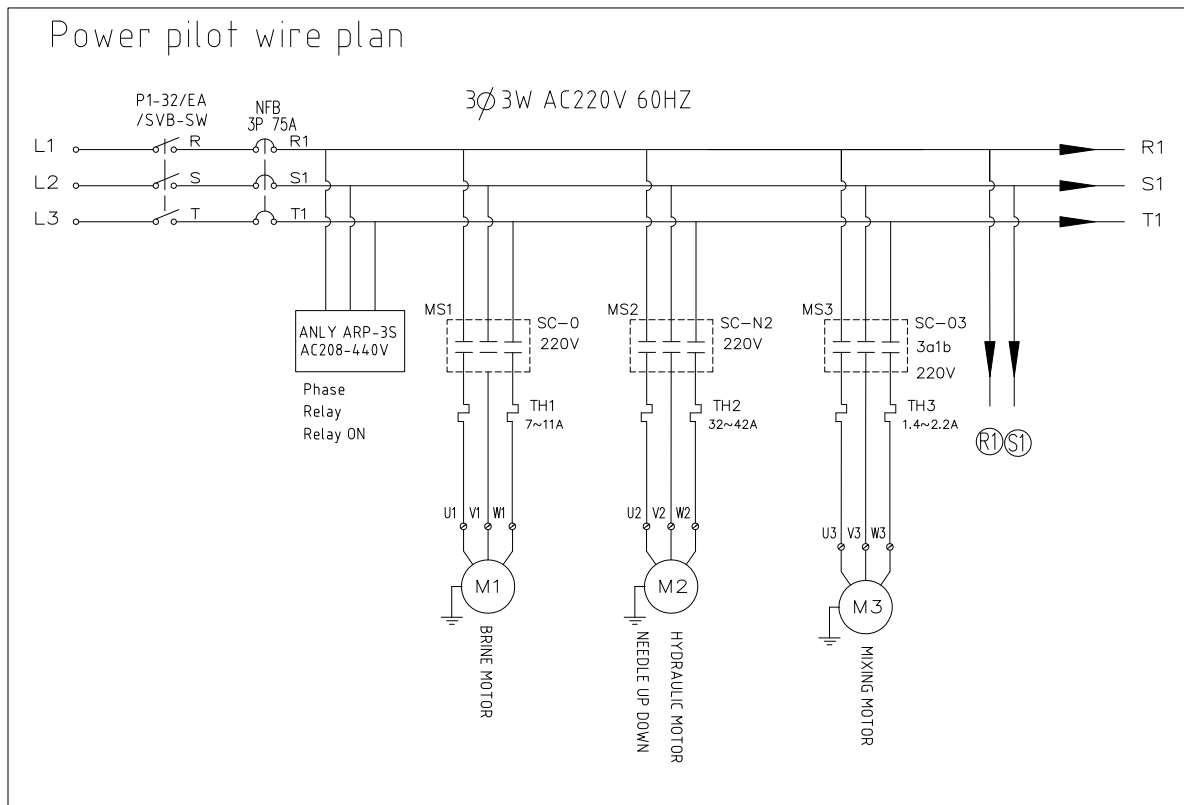

Input wiring diagram

PLC CP1H-XA40DR-A

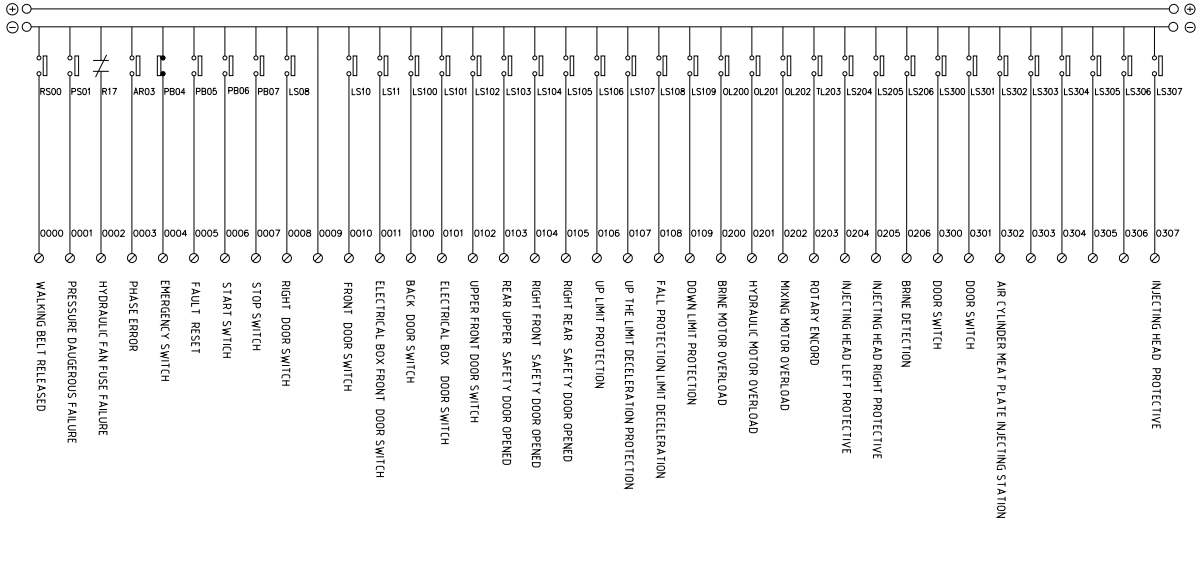

Output wiring diagram

PLC CP1H-XA40DR-A

8ER

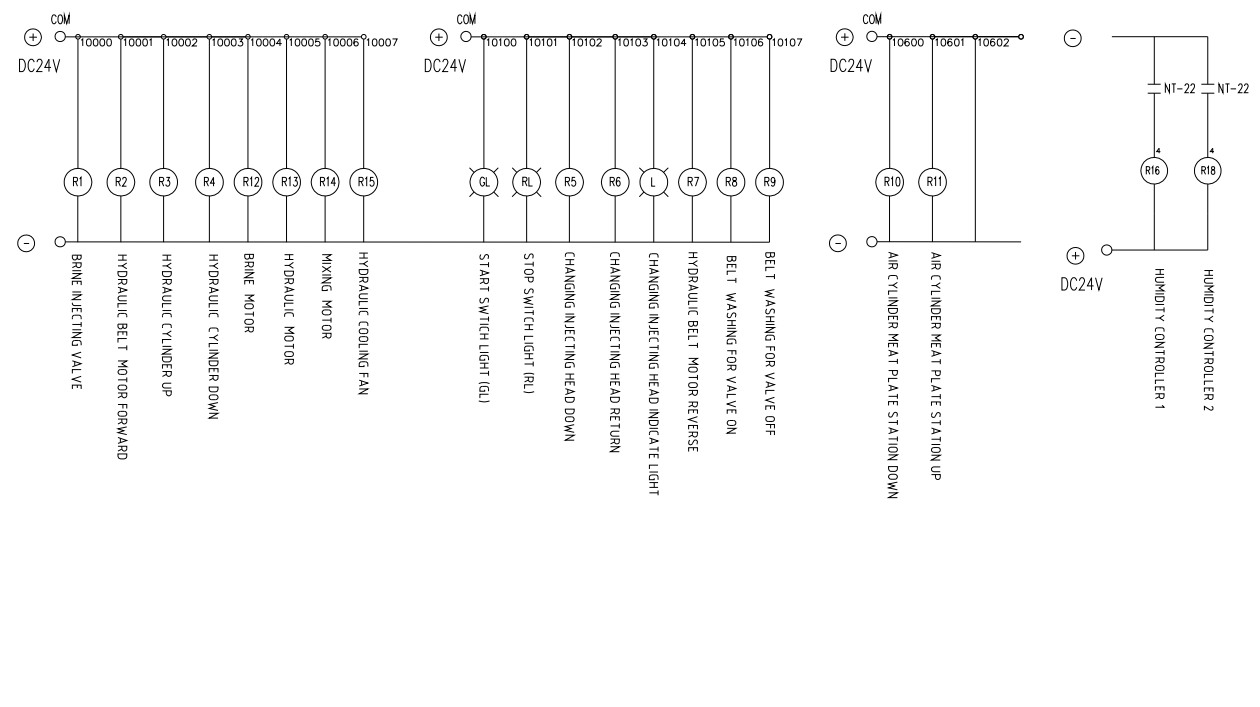

Analogy output wire plan

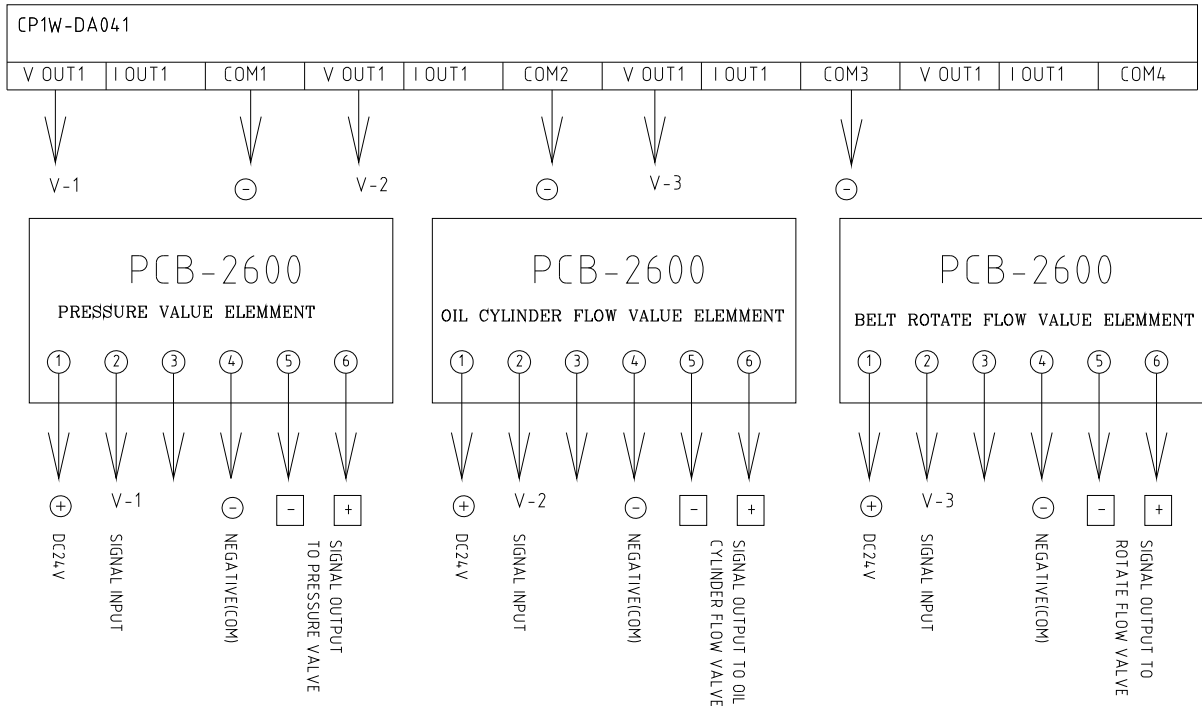

Force dynamics

3 3W AC220V 60HZ

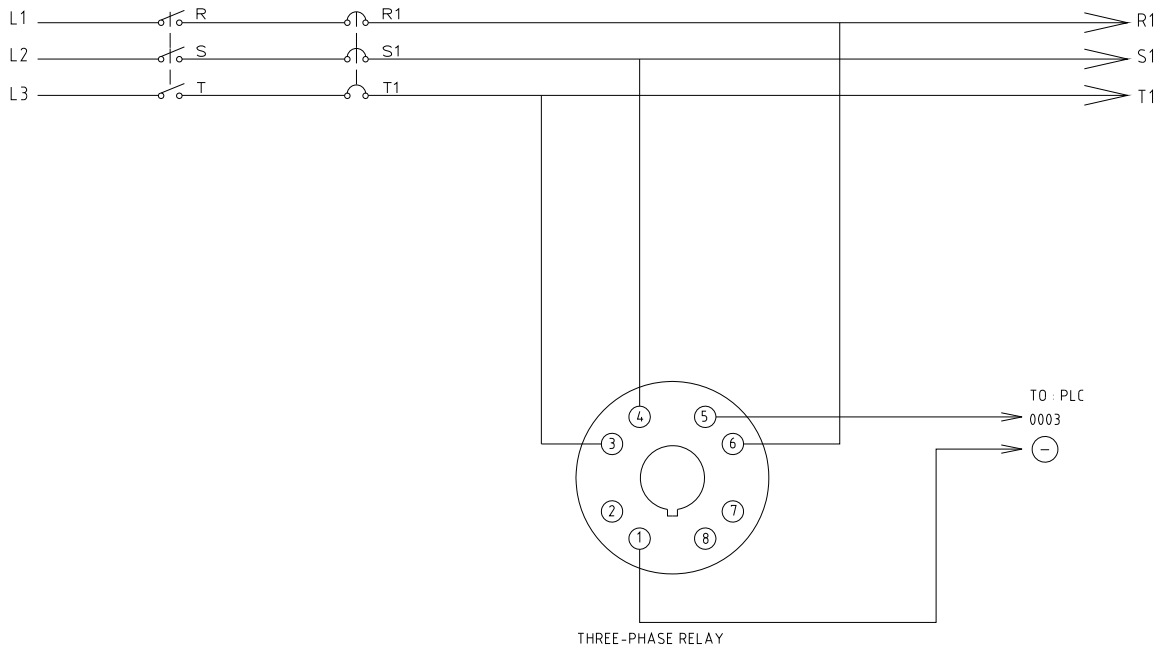

9. Fabrication

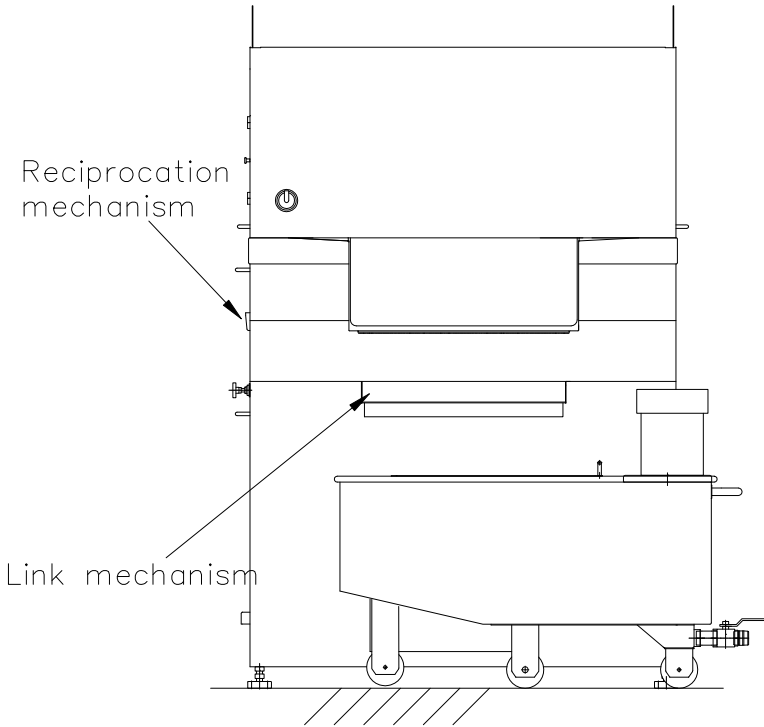
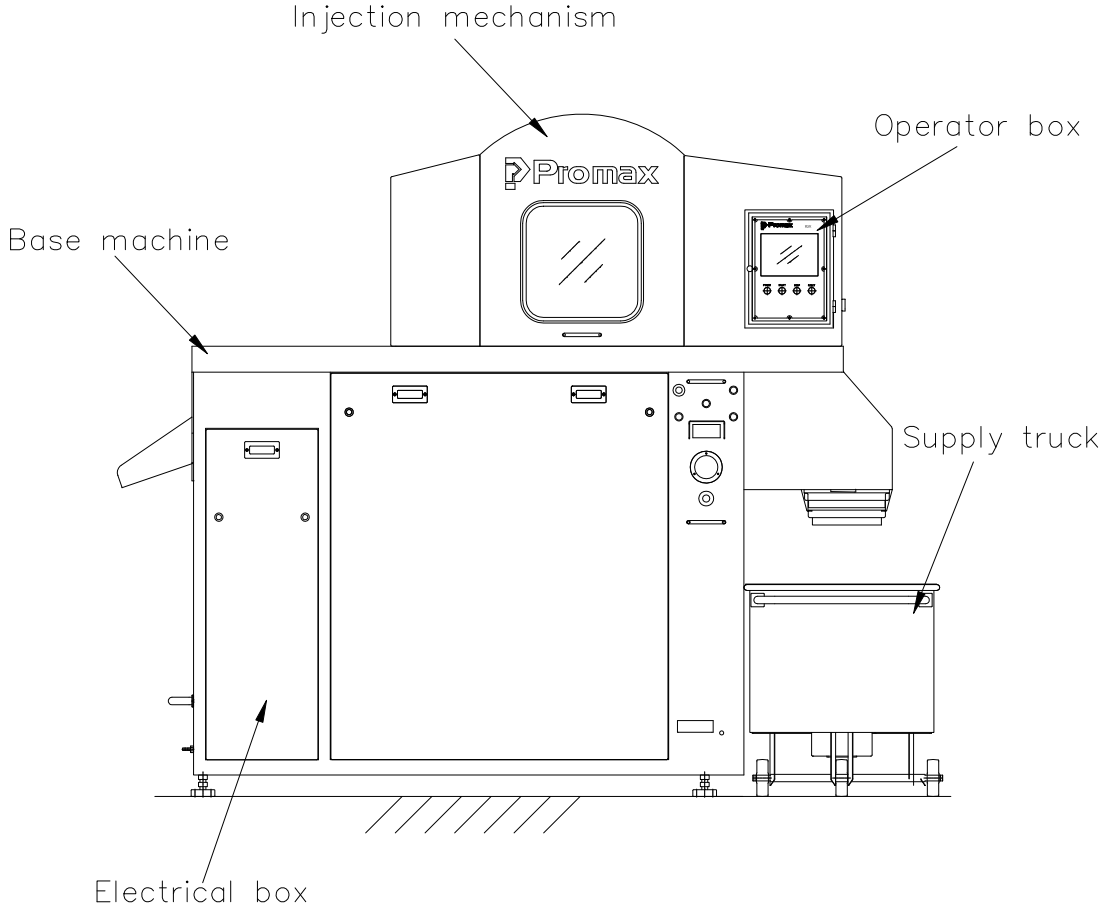

9.1 BASE MACHINE

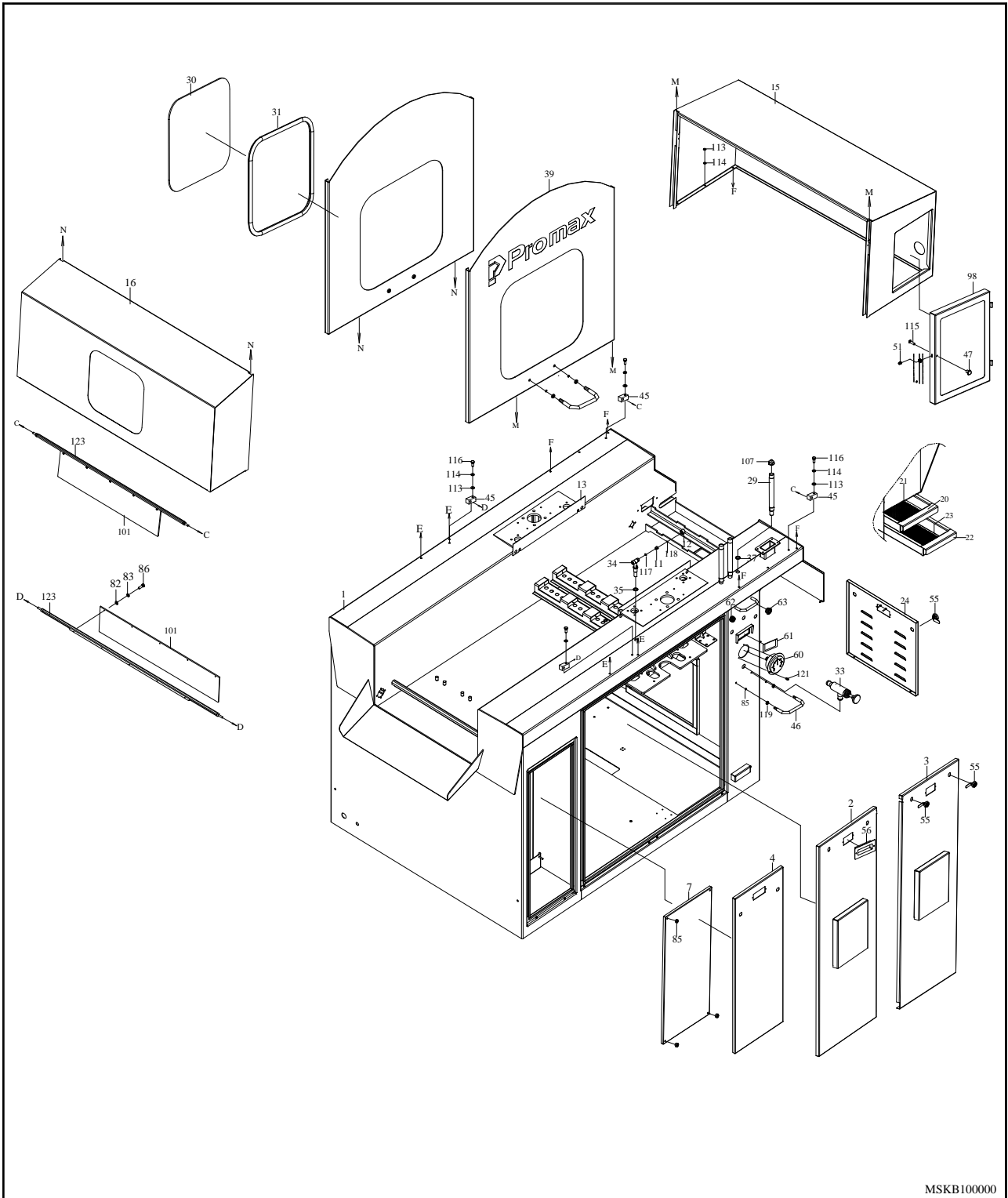

MSKB100000

9.1 BASE MACHINE

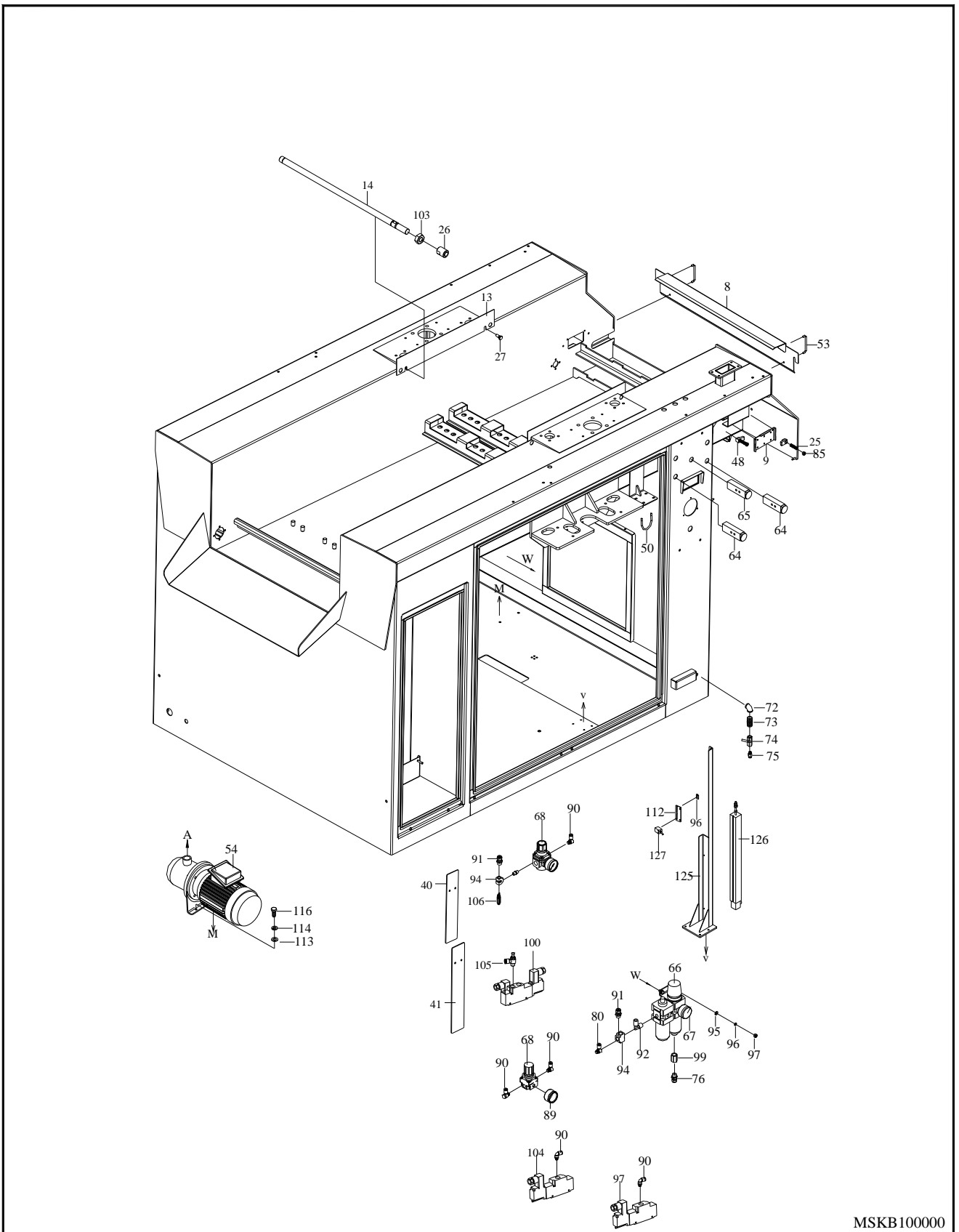

MSKB100000

9.1 BASE MACHINE

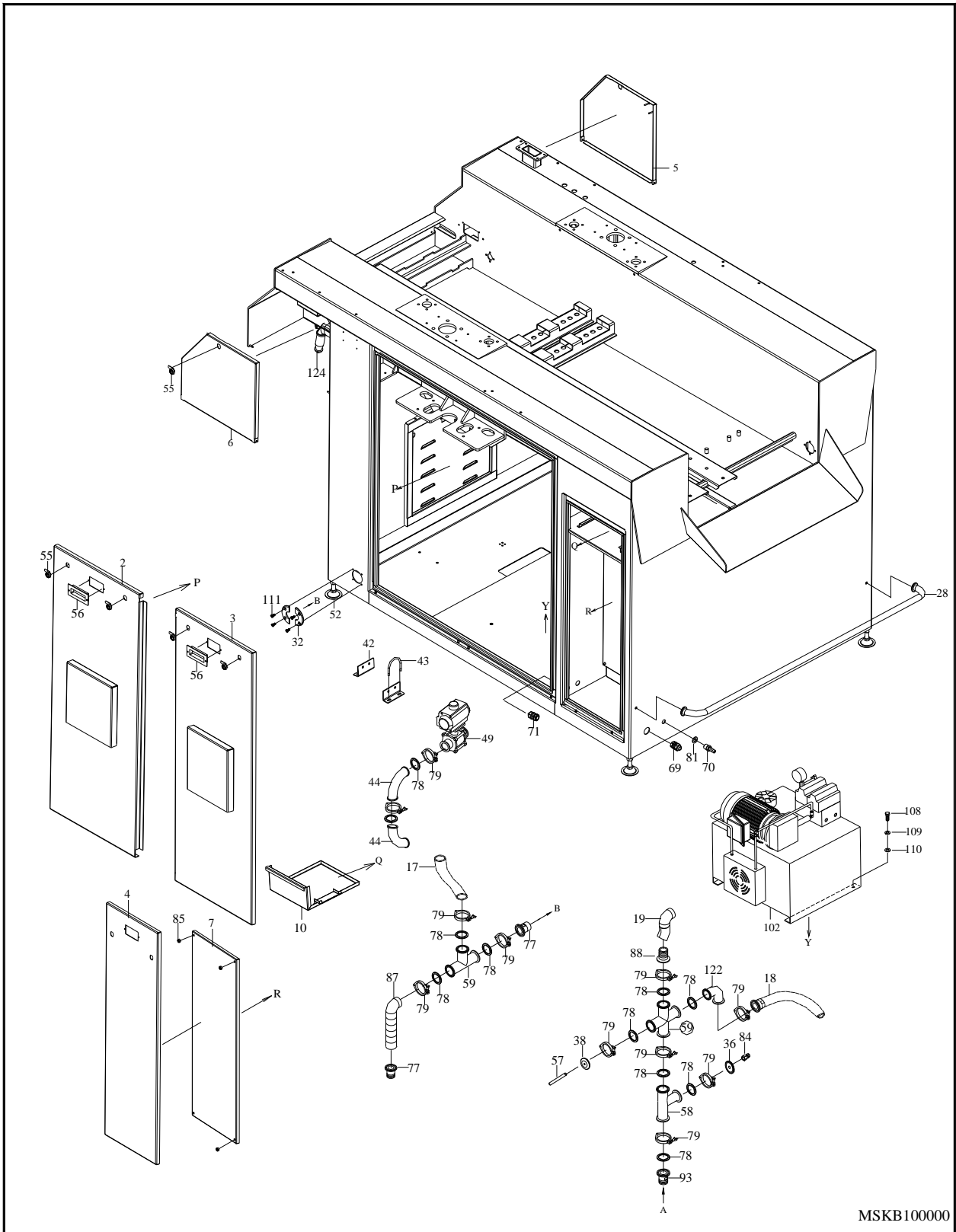

MSKB100000

NO.	PART NO.	DESCRIPTION	QTY	
1	137020A1	Frame	1	
2	MSKA107000	Front door(L)	2	
3	MSKA108000	Front door(R)	2	
4	MSKA109000	Electrical box door	2	
5	MSKA113000	Front right door	1	
6	MSKA114000	Front back door	1	
7	MSKB822000	Panel	2	
8	MSK9119000	Front guide plate	1	
9	MSK9121000	Cover plate	2	
10	MSKA122000	Oil collect plate	1	
11	MSK4142000	O-Ring holder	2	
12	MSK4143000	Cover	2	
13	MSKA145001	Protection plate	2	
14	MSK9146000	Shaft	2	
15	137020A2	Cover door	1	
16	137020A3	Upper left cover	1	
17	MSKA176000	High pressure 1-1/2"	1	
18	MSKA174000	High pressure 1-1/2"	1	
19	MSKA173000	High pressure 1-1/2"	1	
20	MSK8102000	Drawer	1	
21	MSK8103000	Sift net	1	
22	MSK8104000	Drawer	1	
23	MSK8105000	Sift net	1	
24	MSK8106000	Side door	1	
25	MSK4219000	Spring	4	
26	MSK8147000	Nut	2	
27	MSK8148000	Screw	6	
28	MSKA154000	Stopper rod	1	
29	MSK8163000	Air tube mount	3	
30	MSK1119000	Window	3	
31	MSK4115000	Gasket	3	
32	MSK4118001	Plate	2	
33	MSK4130003	Valve	1	
34	MSK4141000	Clean needle set	1	
35	MSK4144000	Washer	3	

NO.	PART NO.	DESCRIPTION	QTY	
36	MSK4151001	Screw fitting	1	
37	MSK4168000	Washer	3	
38	MSK4169000	Sensor mount	1	
39	13702010	Upper cover door	2	
40	MSKB920000	Valve fixed plate	1	
41	MSKB930000	Valve fixed plate	1	
42	MSKA178001	Tube fixed plate	2	
43	2704984	Screw U type 5/16"x1-1/2"	2	
44	2909227	Clamp tee IDF-021 1-1/2"	3	
45	MSK2164001	Water proof plate	4	
46	MSK2606000	Handle	4	
47	MSK2617000	Handle	1	
48	MSK2618000	Press block	4	
49	2909248	Valve 2-WAY 1-1/2"	1	
50	27049834	Screw U type 5/16"x1"	2	
51	2701809	Setting ball M8x1.25	1	
52	27M82537	Base leg	4	
53	2740232	Handle	2	
54	2858010	Switch,motor centrifugal MHI804-R 220V/380V-60HZ	1	
55	2883349	Arm C-408K Key	16	
56	2883142	Arm K-508 Key	5	
57	2856234	Temperature sensor	1	
58	2909190	Clamp tee IDF-022 1-1/2"	2	
59	2909191	Clamp tee IDF-023 1-1/2"	1	
60	2910577	Pressure gauge	1	
61	2856229	Temperature display TC21-ND-PT	1	
62	2933094	Valve Mechanical MVMB-220-3PP-22	1	
63	2870205	Switch,illuminated mushroom AVLW43311-R 24V	1	
64	2933093	Valve Mechanical MVMB-220-4TB-22	2	
65	2933097	Valve Mechanical MVMB-220-3TB-22	1	
66	2910108	Regulator air main MACP 300-10A-D	1	
67	2910550	Pressure gauge 1/8" QPG40-11(PSI&KGF)	1	
68	29100050	Regulator air SMC AR20-02H	2	
69	2861028	Straight connector MG-25A-18G	3	
70	MSK4901000	Fitting	1	

NO.	PART NO.	DESCRIPTION	QTY	
71	2861021	Straight connector MG-20A-14B	2	
72	2740006Z	Fitting 1/4"	1	
73	29092180	Nipple 1/4"x30mm	1	
74	290932770	Fitting 1/4"	1	
75	29091742	Fitting 1/4"x5/16N	1	
76	2909333	Fitting tube JPC802	1	
77	2909207	Adapter with threaded on the end IDF-016 1-1/2"x1-1/4"	1	
78	2909188	Gasket IDF-017 1-1/2"	9	
79	2909189	Heavy duty single pin ciamp IDF-015 1-1/2"	9	
80	29090221	Fitting tube P-74 3/8"	1	
81	2705155	Washer, flat M14	1	
82	2705150	Washer flat M5	10	
83	2705303	Washer split lock M5	10	
84	29091742	Fitting XL-802	1	
85	2707203	Nut, hex hd M8 (S)	16	
86	27000362	Screw hex hd M5x12	10	
87	MSKA175000	High pressure 1-1/2"	1	
88	2909207	Adapter with threaded on the end IDF-016 1-1/2"x1-1/2"	1	
89	2913502	Pressure switch GP46-P10-01L5-X30 DC24V	1	
90	29090312	Fitting SPL802	4	
91	29081003	Fitting SPC10-03	2	
92	2909109	Fitting copper P13-1	1	
93	2909187	Adapter with threaded on the end IDF-016 1-1/2"x1"	1	
94	2909190	Fitting AP87-1 3/8"	1	
95	2705151	Washer flat M6	1	
96	CV1K266000	Switch sensor lock plate	8	
97	2911231	Valve, MVSC220-4E2R-DC24V-L	1	
98	MSK2810001	Stopper shaft	1	
99	2909172	Fitting copper B-23 1/4"x1/4"	1	
100	2911230	Valve, MVSC220-4E2-DC24V-L	1	
101	MSKA118000	Splash guard	2	
102	MSKA901001	Oil pressure unit	1	
103	27070128	Nut M24x3	2	
104	2911229	Valve, MVSC220-3E1-NC-DC24V-L	1	

NO.	PART NO.	DESCRIPTION	QTY	
105	2908015	Fitting JSC602	2	
106	2914058	Valve,Safety SV-02	1	
107	2861037	Straight connector MG-16A-10G	3	
108	2700459	Screw hex hd M12x40	4	
109	2705305	Washer split lock M12	4	
110	2705124	Washer flat M12	4	
111	2702216	Screw flat philip M6x8	4	
112	MSKA823001	Sensor fixed plate	1	
113	2705301	Washer, flat M8	12	
114	2705331	Washer split lock M8	12	
115	2701501	Screw oval hd M6x12	1	
116	2701179	Hex socket hd cap M8x35	6	
117	2740199	O-ring P9	2	
118	2740149	O-ring P4	2	
119	MSK4607000	Noose	4	
121	2701503	Screw oval hd M5x12	3	
122	2909222	Clamp tee IDF-020 1-1/2"	1	
123	MSKA117000	Clamping ledge	2	
124	2844010	Surface mounting sockets 3P+E/16A/480V LEG056359	1	
	2844011	Straight plugs 3P+E/16A/480V LEG055359	1	
125	MSKA822001	Sensor fixed plate	1	
126	2825007	Resistor measure GEFran LT-M-375-S	1	
127	2851005	Switch proximity omron tl-q5mc1	8	

9.2 LINK MECHANISM

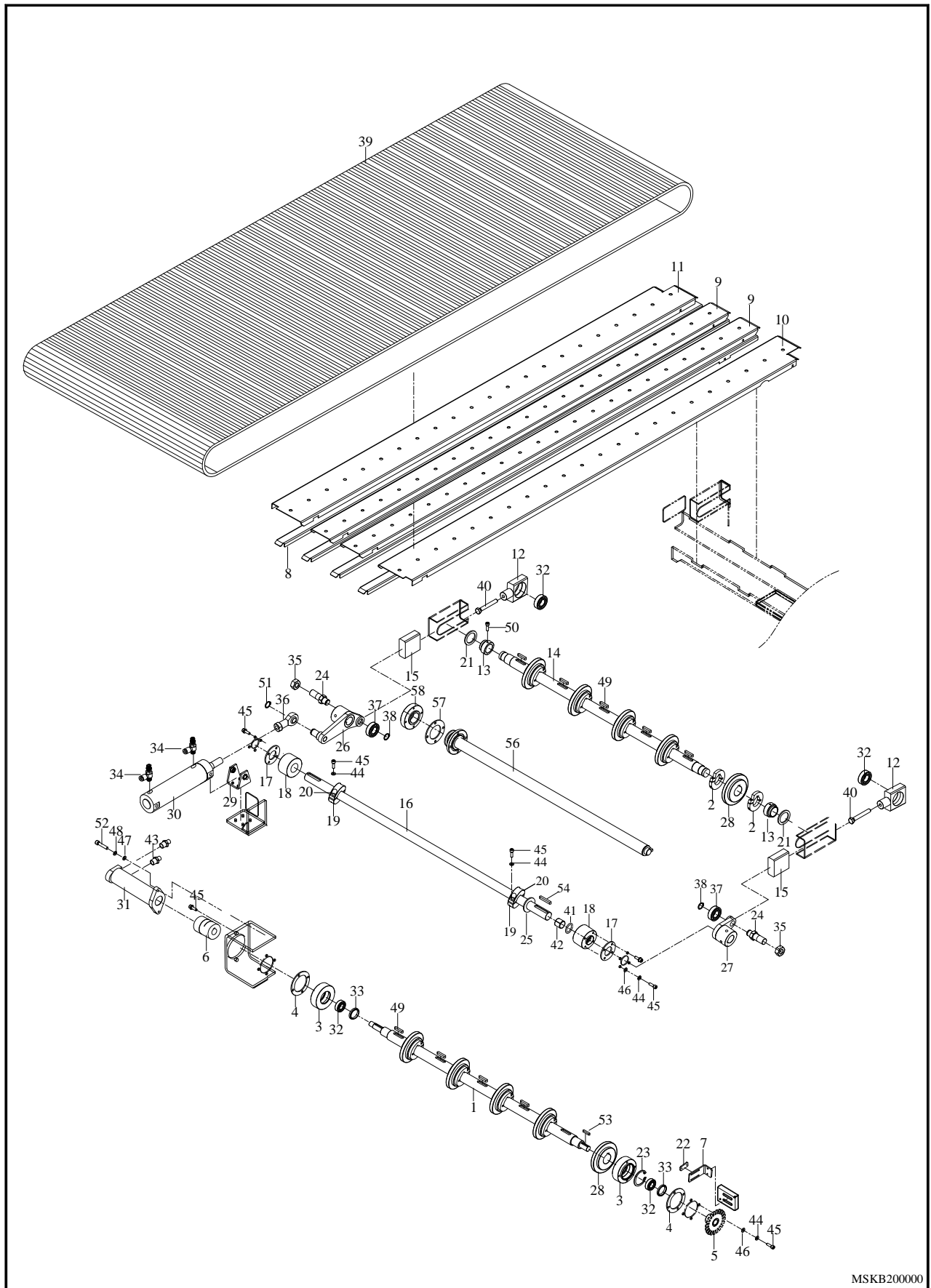

MSKB200000

NO.	PART NO.	DESCRIPTION	QTY	
1	MSKA201000	Driven shaft	1	
2	MSK9202000	Washer	20	
3	MSK9203000	Bearing bracket	2	
4	MSK9204000	Washer	2	
5	MSK9205000	Sensor plate	1	
6	MSKA227000	Couler	1	
7	MSK9207000	Sensor plate	1	
8	MSKA211000	Bottom guiding plate	4	
9	MSKA212000	Top guiding plate	2	
10	MSKA213000	Top guiding plate-F	1	
11	MSKA214000	Top guiding plate- B	1	
12	MSK9213000	Bearing bracket	2	
13	MSK9214000	Bushing	2	
14	MSK9215000	Shaft	1	
15	MSK9216000	Belt adjust slide block	2	
16	MSK9217000	Adjust arm shaft	1	
17	MSK9218000	Washer	2	
18	MSK9219000	Bearing bracket	2	
19	MSK9220000	Plate shaft stop	2	
20	MSK9221000	Retaining ring	2	
21	MSK9222000	Washer	2	
22	MSK9223000	Fixed plate	1	
23	2706035	Ring R47	2	
24	MSK9225000	Shaft	2	
25	MSK9226000	Washer	2	
26	B80K233000	Belt adjust arm	1	
27	BT80234000	Belt adjust arm	1	
28	27140311	Gear 3-CNB-12T	10	
29	2921201	Cylinder plate	1	
30	292018210	Cylinder CDG1UA50-100-C73	1	
31	2920827	Oil motor	1	
32	27280454	Bearing 6005ZZ	4	
33	27400543	Oil sealer	2	
34	2908017	Fitting tube JSC 802	2	
35	27070126	Nut M18x2	2	

9.3 RECIPROCATION MECHANISM

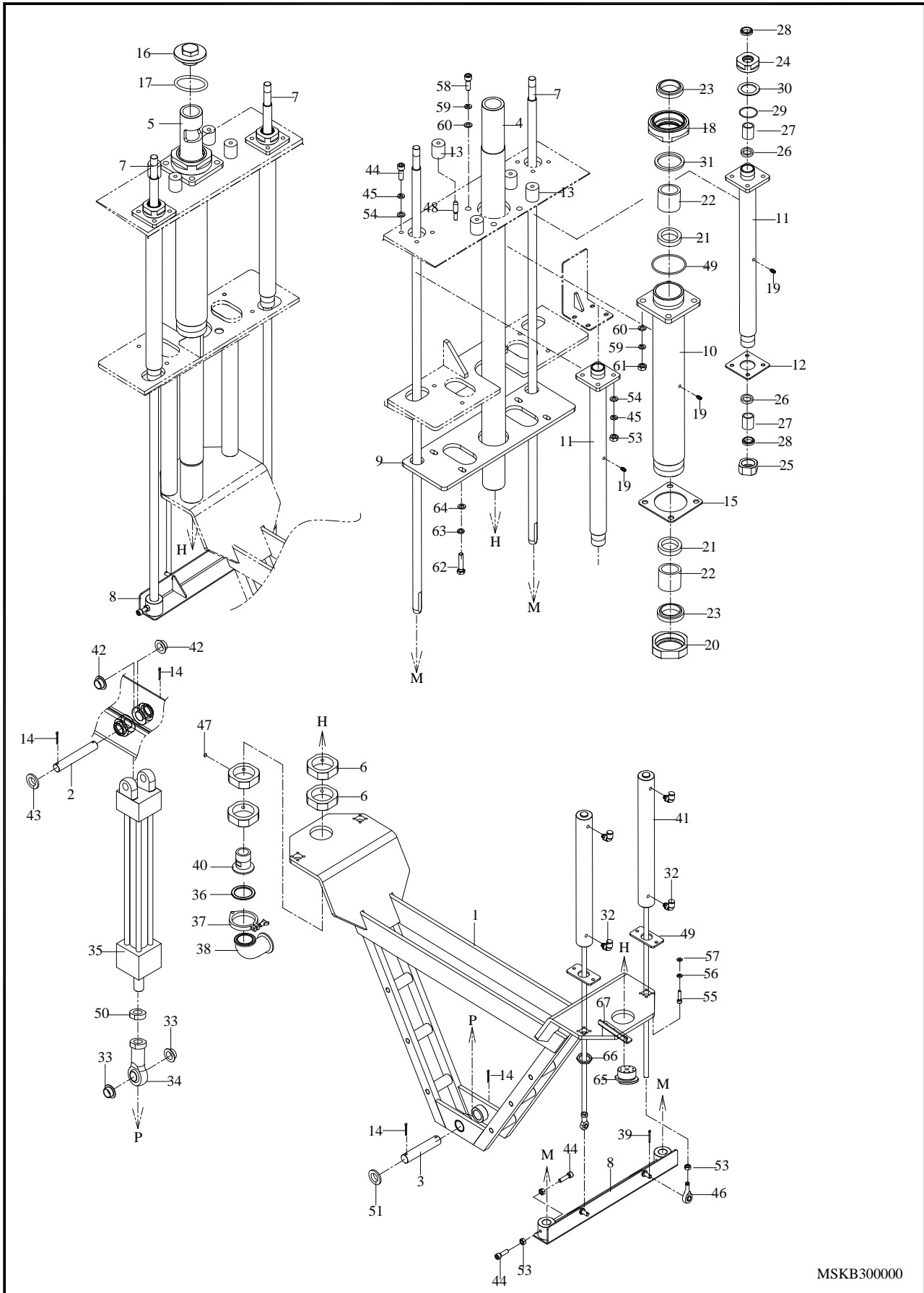

MSKB300000

NO.	PART NO.	DESCRIPTION	QTY	
1	MSKA301001	Strocke cross beam	1	
2	MSKA302000	Shaft for cylinder	1	
3	MSKA303000	Shaft	1	
4	MSKA304000	Towbar(front)	1	
5	MSKA305000	Towbar(back)	1	
6	MSKA306000	Bushing	8	
7	MSKA307001	Meat towbar shaft	4	
8	MSKB308000	Link mount	2	
9	MSKB309000	Plate,shaft base	2	
10	MSK8313001	Bushing	2	
11	MSKA318001	Bushing	4	
12	MSKA311000	Washer	4	
13	MSKA320000	Stopper	8	
14	27433228	Pin	4	
15	MSK9310000	Washer	2	
16	MSK8308000	Colume pipe	2	
17	27401986	O-ring G75	2	
18	MSK8312000	Nut	2	
19	2740140	Nipple, grease 1/8T	6	
20	MSK8314000	Bushing	2	
21	27400537	Oil sealer LBH-55	4	
22	2730288	Bushing JSM-5560-60	4	
23	27400535	Oil sealer UHS-55	4	
24	MSK4317000	Nut	4	
25	MSK4319000	Bushing	4	
26	27400532	Oil sealer UHS-20	8	
27	2730291	Bushing JSM-2026-20	8	
28	27400524	Oil sealer DH-20	8	
29	27401534	O-ring G40	4	
30	MSK4168000	Spacer	4	
31	MSK8311000	Spacer	2	
32	2909057	Fitting A-032-1 1/8	8	
33	27283222	Bearing,BM2220F33	2	
34	2728447	Rod eye,PHS M22x1.5 -R	1	
35	MSKA901001	Cylinder(Oil pressure unit)	1	

NO.	PART NO.	DESCRIPTION	QTY	
36	2909188	Gasket IDF-017 1-1/2"	1	
37	2909189	Heavy duty single pin ciamp IDF-015 1-1/2"	1	
38	2909222	Adapter with threaded on the end IDF-020 1-1/2"	1	
39	27433226	Pin 1/8	4	
40	2909220	Adapter with threaded on the end IDF-016 1-1/2"x1-1/4"	1	
41	29200163	Cylinder CDM2B32-300-XC6	4	
42	272832025	Bearing,BM2025F31	2	
43	2705192	Washer M20	2	
44	2701157	Hexagon socket head cap bolt M8x40 (S)	8	
45	2705301	Spring washer M8	24	
46	27284222	Rod eye,PHS M10x1.25	4	
47	CV1K2A4000	Washer	16	
48	MSK2357000	Stopper shaft	8	
49	MSKA930000	Cylinder fixed plate	4	
50	2707125	Nut M22	1	
51	2909189	Heavy duty single pin ciamp IDF-015 1-1/2"	1	
52	2705129	Washer M22	2	
53	2707203	Nut M8	24	
54	2705152	Washer M8	32	
55	2701167	Hexagon socket head cap bolt M5x20 (S)	16	
56	2705303	Spring washer M5	1	
57	2705150	Washer M5	16	
58	27004573	Hexagon socket head cap bolt M12x40 (S)	8	
59	2705305	Spring washer M12	16	
60	2705137	Washer M12	16	
61	2707209	Nut M12	8	
62	2700443	Screw hex hd M10x35	8	
63	2705304	Spring washer M10	8	
64	2705188	Washer M10	8	
65	MSK8324000	Nut	1	
66	MSKA931000	Nut	4	
67	MSKA824001	Connect plate	1	

9.4 INJECTION MECHANISM

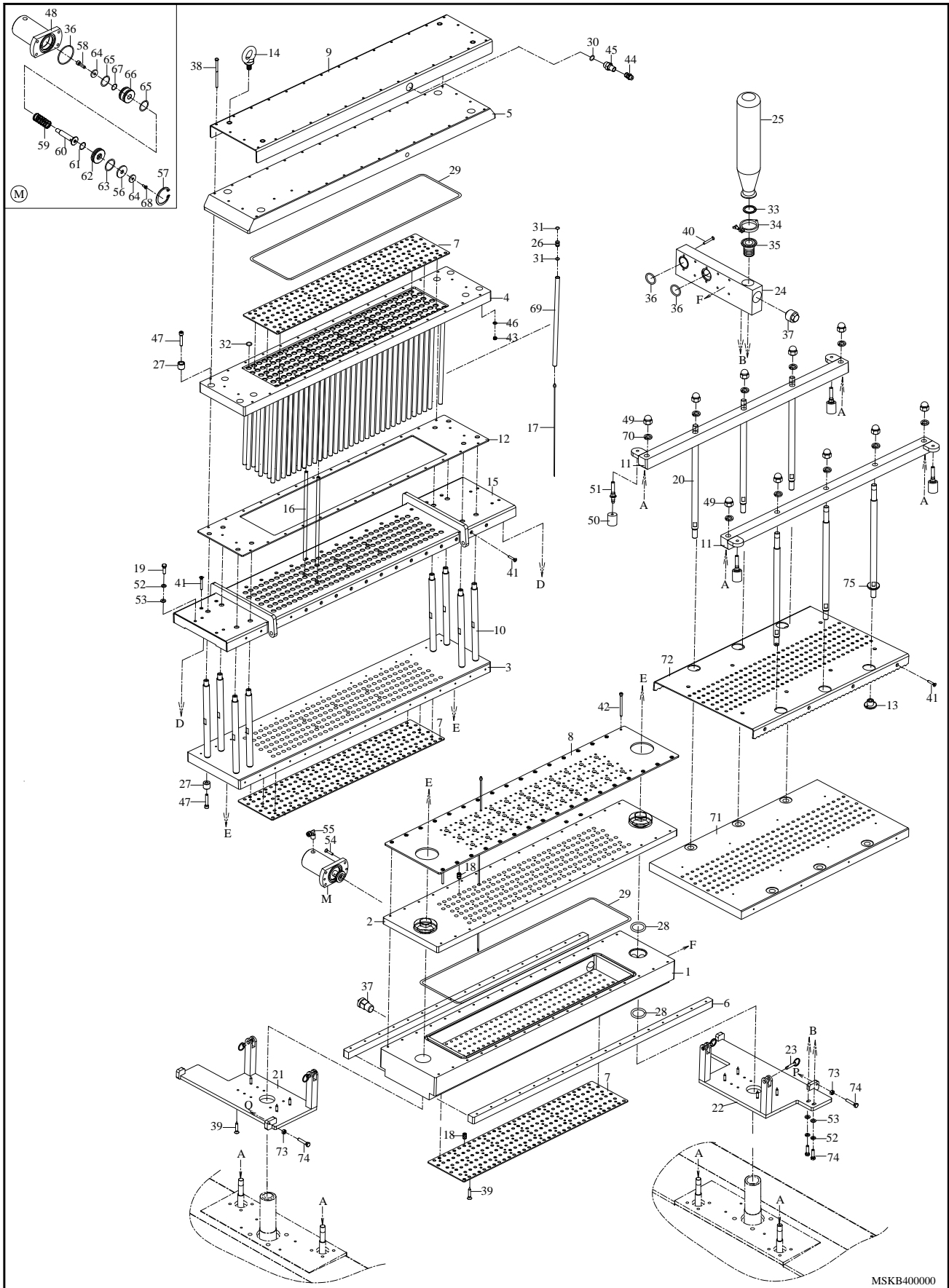

MSKB40000

NO.	PART NO.	DESCRIPTION	QTY	
1	MSKB401000	Holder, guider cover	1	
2	MSKB402000	Holder, guider cover	1	
3	MSKB403000	Bracket, mounting tube	1	
4	MSKB404000	Plate, mounting tube	1	
5	MSKB405000	Plate	1	
6	MSKA406000	Plate	2	
7	MSKB407000	Plate, guider needle	3	
8	MSKB408000	Plate, guider needle	1	
9	MSKB410000	Plate, cover	1	
10	MSK2415000	Post	8	
11	MSKA436000	Bracket	2	
12	MSKB419000	Pad	1	
13	MSK8433000	Plate, nut	6	
14	27049771	Rings screw M12	4	
15	MSKB413000	Mounting tube fixed plate	1	
16	MSK8454000	Post	6	
17	MSK8461000	Needle	98	
18	MSK4421A00	Bushing,needle set	196	
19	MSK8434000	Disc	6	
20	MSKA435000	Fixed shaft	6	
21	MSKB416000	Bracket	1	
22	MSKB417000	Bracket	1	
23	MSK8423000	Pin set	4	
24	MSK8425000	Store press fixed mount	1	
25	MSK8426000	Store press bottle	1	
26	MSK4412000	Piston	98	
27	MSK4414000	Bushing	16	
28	27401551	O-ring Ø52xØ4	2	
29	27401559	O-ring AS471	2	
30	27401573	O-ring P16	1	
31	27401582	O-ring Ø8xØ2	196	
32	27401574	O-ring P13	98	
33	2909188	Gasket IDF-017 1-1/2"	1	
34	2909189	Heavy duty single pin ciamp IDF-015 1-1/2"	1	
35	2909220	Adapter with threaded on the end IDF-016 1-1/2"x1-1/4"	1	

NO.	PART NO.	DESCRIPTION	QTY	
36	27401552	O-ring Ø35xØ4	2	
37	28672981	Cap 1-1/4"	2	
38	27000674	Screw, hex hd M6x100 (S)	32	
39	27004116	Screw,flat philip M6x20(S)	148	
40	27004118	Screw,flat philip M6x60(S)	10	
41	27004114	Screw,flat philip M6x30(S)	77	
42	27000678	Hex socket hd screw M6x110	34	
43	27071102	Acorn nut M6 (S)	32	
44	29090429	Fitting nylon tube A-015	1	
45	MSK4420000	Fitting	1	
46	2705302	Washer, split lock M6 (S)	32	
47	2701157	Hex socket hd cap M8x40	16	
48	MSK8442000	Cylinder body	1	
49	27071104	Acorn nut M16 (S)	10	
50	MSK2438001	Bushing	4	
51	MSKA437000	Stopper shaft	4	
52	2705301	Washer, split lock M8 (S)	30	
53	2705152	Washer, M8 (S)	30	
54	27004115	Screw,flat philip M6x25(S)	6	
55	2909328	Fitting nylon tube SPL602	1	
56	MSK8445000	Pad	1	
57	27062051	Ring R52	1	
58	2701168	Hex socket hd screw M8x16	1	
59	MSK8447000	Spring	1	
60	MSK8444000	Shaft	1	
61	2740163	O-ring P21	1	
62	MSK8443000	Side cover	1	
63	27401584	O-ring P46	1	
64	MSK8446000	Touch plate	2	
65	27401583	O-ring P44	2	
66	MSK8448000	Piston	1	
67	27401573	O-ring P16	1	
68	2702273	Screw flat philip M8x20	1	
69	MSK2411000	Mounting tube	98	
70	2705328	Spring washer M16	10	

9.5 SUPPLY TRUCK

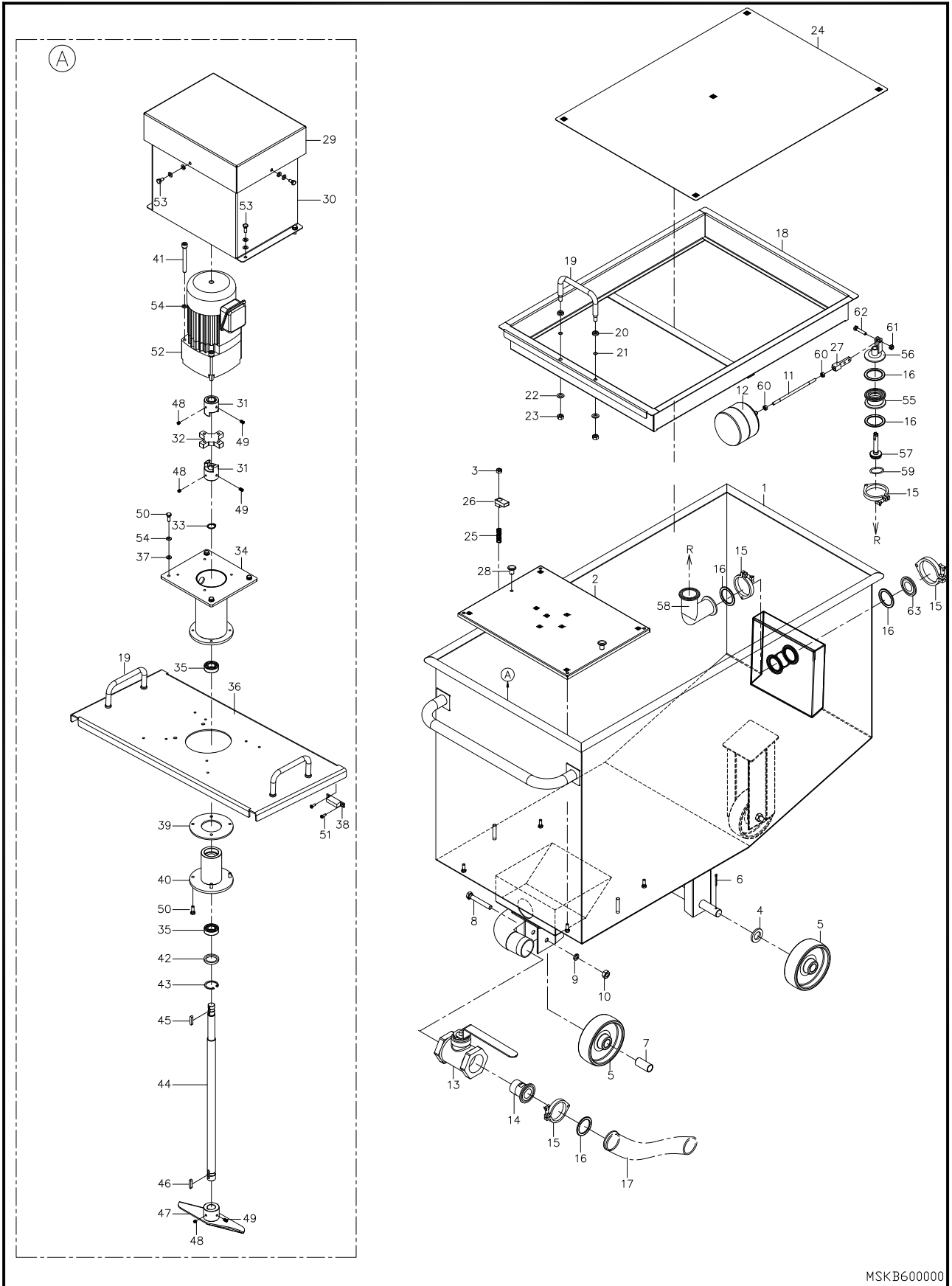

MSKB600000

NO.	PART NO.	DESCRIPTION	QTY	
1	MSKB601000	Barrel	1	
2	MSK4608001	Sift net	1	
3	27070222	Nut, hex hd M8 (S)	2	
4	2705185	Washer, flat M20 (S)	2	
5	PB20102000	Caster	4	
6	27433227	Pin	2	
7	PB20103000	Bushing	2	
8	274531202	Screw, hex hd M10x60 (S)	2	
9	2705304	Washer, split lock M10 (S)	2	
10	2707017	Nut, hex hd M10 (S)	2	
11	MSKA621000	Float cock arm	1	
12	MSKA622000	Float cock	1	
13	2909206	Valve 1-1/2"	1	
14	2909207	Adapter with threaded on the end IDF-016 1-1/2"x1-1/2"	1	
15	2909189	Heavy duty single pin ciamp IDF-015 1-1/2"	4	
16	2909188	Gasket IDF-017 1-1/2"	5	
17	MSK4175001	Input tube 1-1/2"	1	
18	MSK8605000	Frame	1	
19	MSK2606000	Handle	3	
20	MSK4607000	Noose	6	
21	27401570	O-Ring P8 (FPM.V.T)	6	
22	2705301	Washer, flat M8 (S)	2	
23	2707203	Nut, hex hd M8 (S)	2	
24	MSK8616000	Sift net	1	
25	MSK4219000	Spring	2	
26	MSK2618000	Press block	2	
27	MSKA620000	Rod	1	
28	MSK2617000	Handle	2	
29	MSK2615000	Cover	1	
30	MSK2614000	Plate, cover	1	
31	A1122000	Couler	2	
32	A1125000	Rubber, coupling spacer sbllt	1	
33	2706031	Ring S17(S)	1	
34	MSK4612000	Plate, mount	1	

NO.	PART NO.	DESCRIPTION	QTY	
35	27280045	Bearing 6003ZZ	2	
36	MSK8610000	Plate, mount	1	
37	2705151	Washer, flat M6 (S)	16	
38	2852191	Magnetic sensor airtac OMRON GLS-1 OMS	1	
39	MSK4612040	Washer	1	
40	MSK4613000	Plate, bearing	1	
41	2701155	Hexagon socket hd cap M6x80	4	
42	27400525	Oil sealer	1	
43	2706033	Ring R35	1	
44	MSK8611000	Shaft, agitate	1	
45	2709001	Key	1	
46	MSK4617000	Key	1	
47	MSK2609000	Fan, agitate	1	
48	2704601	Screw, socket set M6x6	3	
49	2704603	Screw, socket set M6x10	3	
50	2700402	Screw, hex hd M6x16 (S)	8	
51	2703308	Screw, round hd M4x12	2	
52	28320M17RW	Gear motor, 3PH 200V~240V 1/17 LH	1	
53	2700401	Screw, hex hd M6x12 (S)	8	
54	2705302	Washer, split lock M6 (S)	16	
55	MSKA617000	Valve body	1	
56	MSKA618000	Valve body cover	1	
57	MSKA619000	Piston	1	
58	2909227	Adapter IDF-021 1-1/2 ELBOW 90	1	
59	27401977	O-Ring P22A	1	
60	2707204	Nut M6	2	
61	2707110	NUT NYLOCK M6	2	
62	2700462	Screw, hex hd M6x30 (S)	2	
63	2909225	Adapter IDF-014 1-1/2"	1	

9.6 OPERATOR BOX

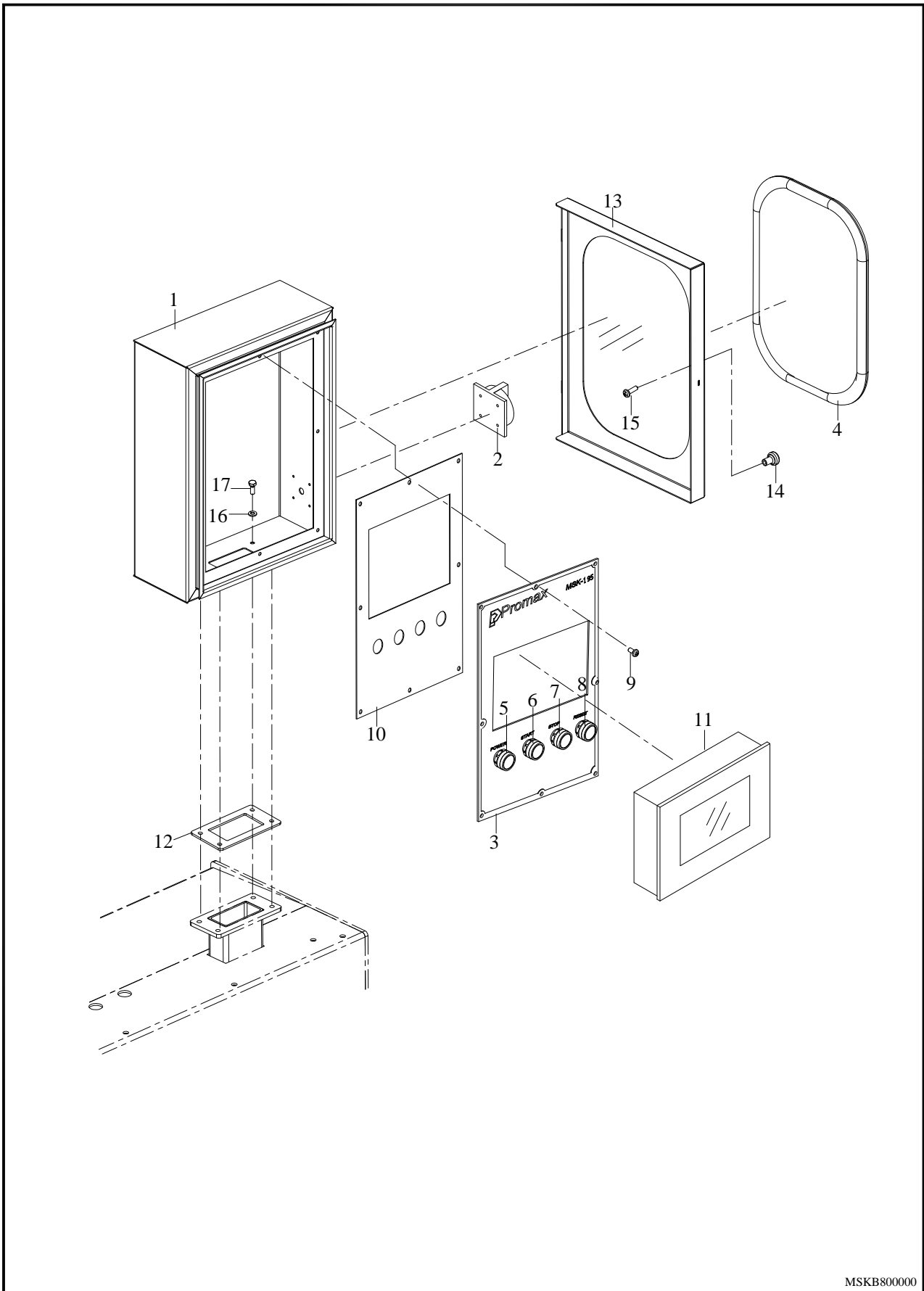

MSKB800000

NO.	PART NO.	DESCRIPTION	QTY	
1	MSKB801000	Operator box	1	
2	28017126	Switch MOELLER P3-63/EA/SW	1	
3	MSBA805000	Control panel	1	
4	MSK2810031	Gasket	1	
5	2871740	Indicator lamp, white TE ZB4-BV01	1	
	2871748	Body, indicator lamp TE ZB4-BV6	1	
	2871752	bulb TE DL1-CF220	1	
6	2871761	illuminated pushbutton head TE ZB4-BW33	1	
	2871748	Body, indicator lamp TE ZB4-BV6	1	
	28704981	bulb AB-9G-DC24V LED24V	1	
	2871737	circuit breaker	8	
7	2871762	illuminated pushbutton head	1	
	2871748	Body, indicator lamp TE ZB4-BV6	1	
	28704984	bulb AB-9R-DC24V LED24V	1	
	2871737	circuit breaker	1	
8	2871704	Button TE ZB4-BA5	1	
	2871737	Switch, contact TE ZB4-BZ101	1	
9	2703332	Screw, round hd M6x10	4	
10	MSK2802002	Control fixed plate	1	
11	2827045	Human interface Pro-face PFXGP4301TADW	1	
12	MSK2809000	Washer	1	
13	MSK2810001	Operator platr cover	1	
14	MSK2617000	Handle	1	
15	2701501	Screw, round hd M6x12	1	
16	2705313	Split lock washer	1	
17	2700415	Scerw, hex hd M8x16	1	

9.7 ELECTRICAL BOX

Material disposition chart 1

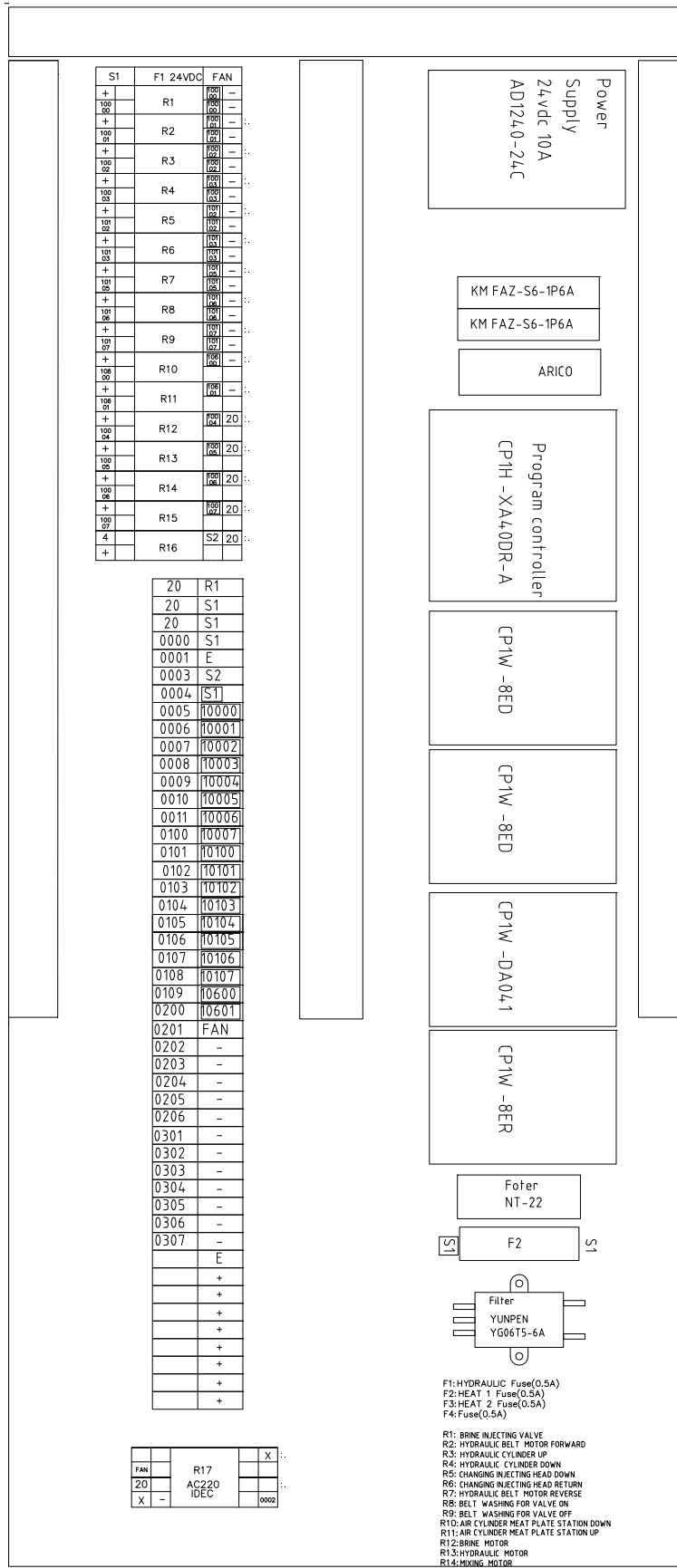

220V MSK-98

9.7 ELECTRICAL BOX

Material disposition chart 2

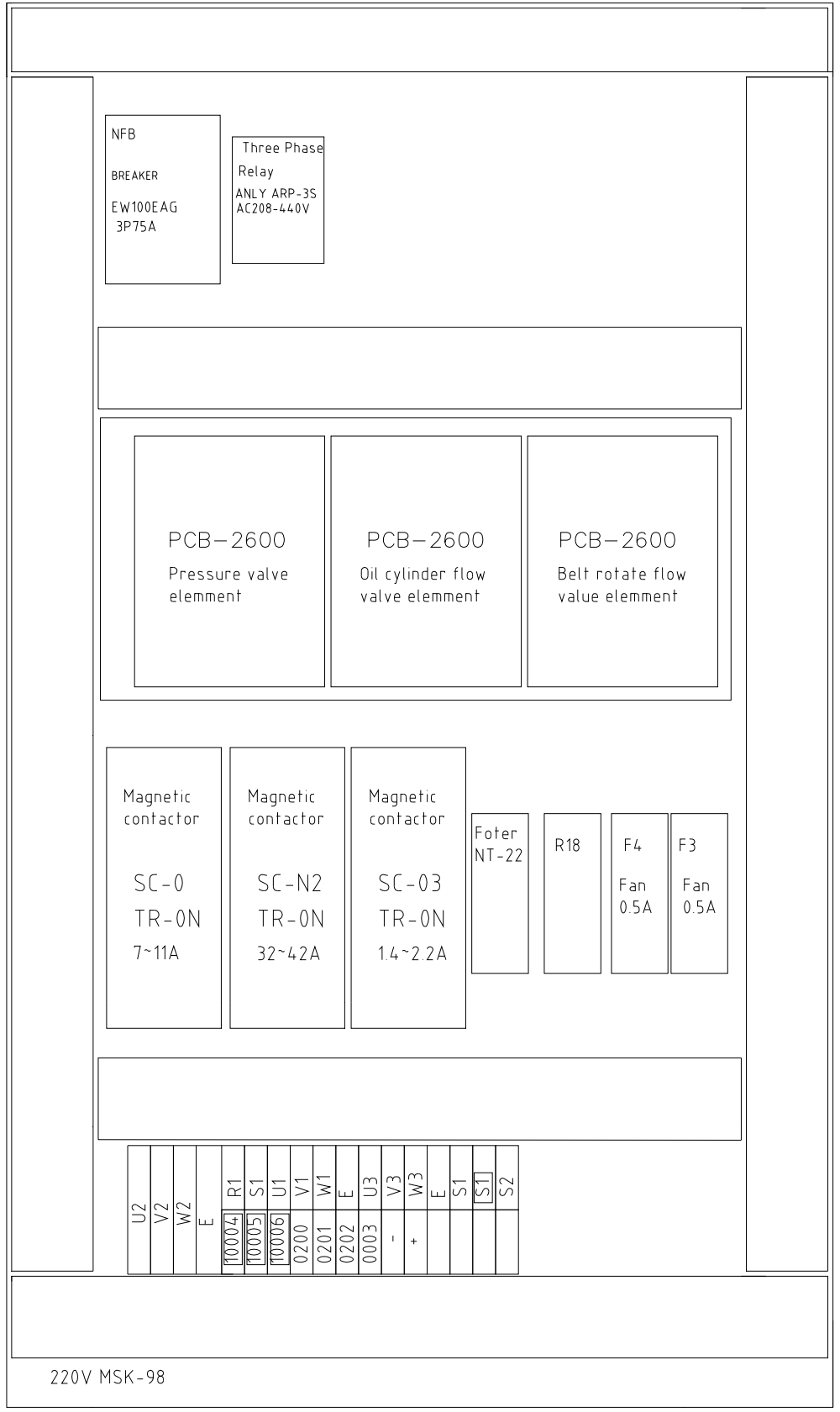

9.7 ELECTRICAL BOX

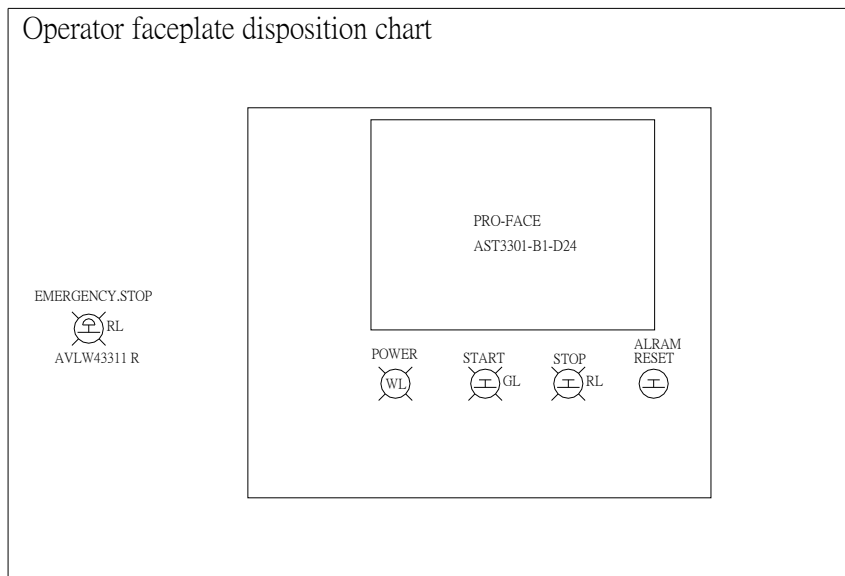

NO	PART NO.	SPECIFICATION
1(50)	28560225	Heater,PTC-100 100W AC220V
2	2896530-9	SUPPLY POWER, AD1150-24F 150W6A
3,4	2801825	SWITCH KM FAZ-S6 1P6A
5	2806103	ADAPTER, SIGNAL, F/MSK-98S PLC
6	28201005	CP1H-XA40DR-A , F/MSK-98S PLC
6.1	2824569	PORT, RS232(CP1W-CIF01), F/MSK-98S PLC
7,8	28201013	EXTENSION MODULE, CP1W-8ED, F/MSK-98S PLC
9	2820427	MODULE, OMRON CP1W-DA041, F/MSK-98S PLC
10	28201012	EXTENSION MODULE, CP1W-8ER, F/MSK-98S PLC
11(44)	2827307	CONTROLLER, TEMPERATURE,NT-22R
12	28900231	HOLDER, FUSE, SF-111AE UL
13	28961071	FILTER,YUNPEN Y06TS-10A
14	28900231	HOLDER, FUSE, SF-111AE UL
15-30(45)	2830137	RELAY, RJ2S-CL-D24
15-30(45)	2831107	BASE, RELAY SY4S-05D
31	2810271	RELAY,IDEC RU4S-C-A220
	2831106	BASE, RELAY SY4S-05D
32	2843204*45	TERMINAL, BLOCK PUW-20
32	2843205*1	PLATE, TERMINAL BLOCK SIDE PUW-20L
33	2802024	CIRCUIT BREAKER,EW100 EAG 3P 75A
34	2831054	RELAY ARP-3S
35.36.37	2913357	CONTROL BOARD, PROPORTIONAL VALVE, PCB-2600, F/MSK-98S
38	28102294	RELAY,SC-0 A 220V
39	2811193	RELAY,THERMAL FUJI TRON 7-11A
40	28102293	RELAY ,SC-N2 A 220V 50/60HZ
41	2811198	RELAY, OVERLOAD,FUJI TR-N2 32-42A
42	2810218	MAGNETIC SWTICH, SC-03 3a1b 220V, F/MSK
43	2811186	RELAY,THERMAL FUJI TRON 1.4-2.2A
44	2827307	Temperture controller
45	2830137	Relay
45	2831107	BASE, RELAY SY4S-05D

9.7 ELECTRICAL BOX

46	28900231	HOLDER, FUSE, SF-111AE UL
47	28900231	HOLDER, FUSE, SF-111AE UL
48	2843213*4	TERMINAL, BLOCK PTU-80
48	28432131*1	TERMINAL, BLOCK PTU-80L
49	2843204*17	TERMINAL, BLOCK PUW-20
49	2843205*1	PLATE, TERMINAL BLOCK SIDE PUW-20L
50	28560225	PTC-100 100W AC220V

10. Packing List

NO.	PART NO.	DESCRIPTION	QTY	NOTE
1	@MSK-98	MSK-98 brine injector	1	
2	MSKB601000	Brine vessel	1	
3	MSK2609A00	Agitator	1	
4	13702010	Side door	2	
5	137020A2	Upper Right door	1	
6	137020A3	Upper Left door	1	
7	MSK-98	Brine injector introduction	1	
Vulnerable parts :				
1	2740149	O-ring P4	104	
2	27401582	O-ring P8	104	
3	27401552	O-ring ϕ 35x ψ 4	1	
4	27401551	O-ring ϕ 52x ψ 4	1	
5	27400535	Oil sealer UHS-55	4	
6	27400537	Oil sealer LBH-55	4	
7	27400524	Oil sealer DH-20	4	
8	27400532	Oil sealer UHS-20	4	
9	2730291	Bushing JUM-02-20	8	
10	2730288	Bushing JSM-5560-60	4	
11	MSK8461000	Needle (include spare 6 pieces)	104	
12	MSK4412000	Piston	12	

11. Needle Cleaning and Lubrication Procedure

Caution/Alert

Step 1 – Turn “Needle Air” switch to off position.



Step 2 – Locate Push pins. Remove the two pins on the head, on the in-feed side.

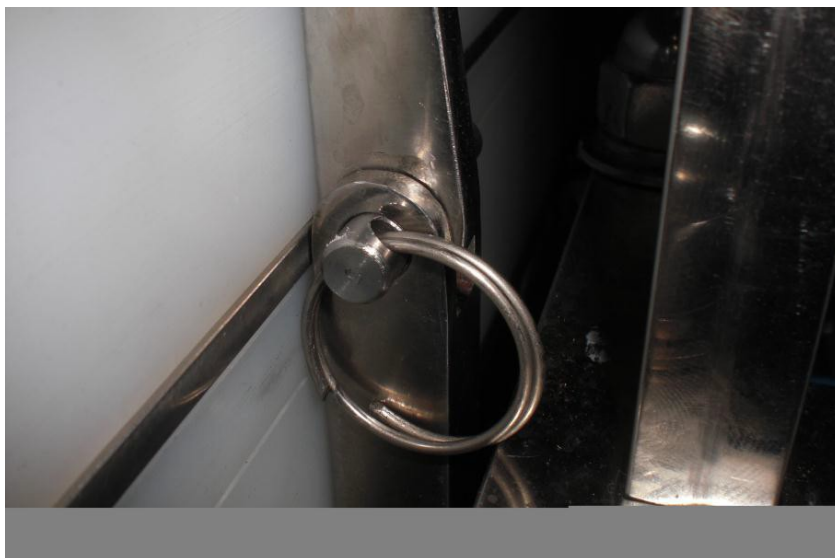

Step 3 – Carefully open the head, only enough to verify all needles are in the down position.
if any needles are still in the raised position in the head, pull them down. Next finish opening the head until it rests on the white resting blocks.

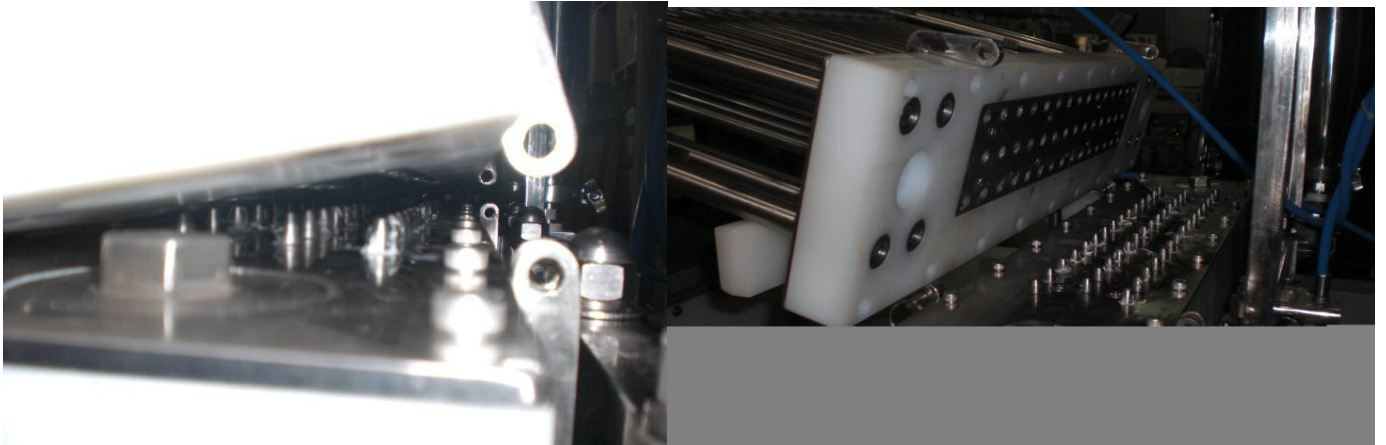

Step 4 – Remove all needles by pulling straight up on the needle tops.



Step 5 – Insert each needle into the needle cleaner and press the “ Needle Clean” button to remove food material from inside the needles .



Step 6 – Before re-installing needles you must apply a thin coat of lube to each needle.



Step 7 – Re-install needles, insuring they are pushed all the way down firmly.



Step 8 – Add a small amount of lube to top tip of needles to lube the upper needle cylinders.



Step 9 – Additionally add a small amount of lube to each piston cylinder



Step 10 – Close head and re-install push pins.



Step 11 – Turn “Needle Air” switch back to “On” position



Note: Never operate machine with the “Needle Air” Switch in the “Off” position or without air connected to the machine. As this will cause damage to the needles and other components.