

DC Series Vacuum Chamber Packaging Machines

Technical Specifications

MODELS	DC-530	DC-640	DC-650	DC-800	DC-860	DC-900
Chamber Size (F) (H)	30"/760mm 23.6"/600mm	32.2"/818mm 28.9"/734mm	32.2"/818mm 35"/890mm	38.6"/980mm 31"/787mm	41.3"/1050mm 40.6"/1030mm	48"/1218mm 41.6"/1057mm
Chamber Depth (E)	8"/203mm	8.3"/210mm	8.4"/213mm	10"/255mm	10"/255mm	12.5"/317.5mm
Distance Between Seal Bars (B)	16.7"/425mm	22"/560mm	28.1"/715mm	24.2"/615mm	33.8"/858mm	34.9"/887mm
Seal Length (A)	21.3"/540mm	25"/634mm	25.4"/646mm	31.4"/800mm	34.3"/870mm	39.4"/1000mm
Vacuum Pump Capacity	40m3/h (1.3kw)3.6A	63m3/h (1.8kw)4.3A	100m3/h (2.5kw)6.3A	100m3/h (4hp/2.5kw) 6.3A	305m3/h (12hp/8.9kw) 14.9A	305m3/h (12hp/8.9kw) 14.9A
Voltage	220V/3ph/50Hz	220V/3ph/50Hz	220V/3ph/50Hz	220V/3ph/50Hz	220V/3ph/50Hz	220V/3ph/50Hz
Machine Size CxGxD	1480x640x1140mm 58"x25"x45"	1580x775x1145mm 62"x31"x45"	1580x930x1000mm 62"x37"x39"	1900x830x1190mm 75"x33"x47"	2060x1075x1210mm 81"x51"x48"	2376x1097x1260mm 94"x43"x50"
Machine Weight	657 lbs.(298kg)	908 lbs.(412kg)	1217 lbs.(552kg)	1261 lbs.(572kg)	2150 lbs.(955kg)	2337 lbs.(1060kg)

DC Series vacuum chamber packaging machines have been designed for economical, single operator efficiency.

Standard Features:

- Stainless steel construction
- Flat chamber for easy cleaning
- **PD-01** Basic digital control panel (Model DC530)
- **PNC-01** (except DC530) Computerized water resistant control panel (Ip56)
(14 programs with oil indicator)
- 100 wide seals
- Bladder activated sealing
- High density plastic filler boards
- Pump overload warning indicator (except DC530)
- Oil change indicator
- Vacuum sensor controls (DC-860/900)
- Heavy duty casters
- Air assist regulator
- Automatic lid transformer (DC-900)

***Hide away control panel for wash down*(See pic#1)**

***Quick seal bar disconnect w/o tool requirement*
(See pic#2)**

Optional Features:

- **PNC-01** (for model DC530)
- Single phase motor available up to 100m3/h (5hp) pump
- Top & bottom seal
- Gas flush
- Chamber height
- Mechanical knife cut-off system
- Automatic lid transformer (DC-560/640/650/800/860)
- Voltage
- Pump horsepower upgrade
- Custom chamber sizes are available

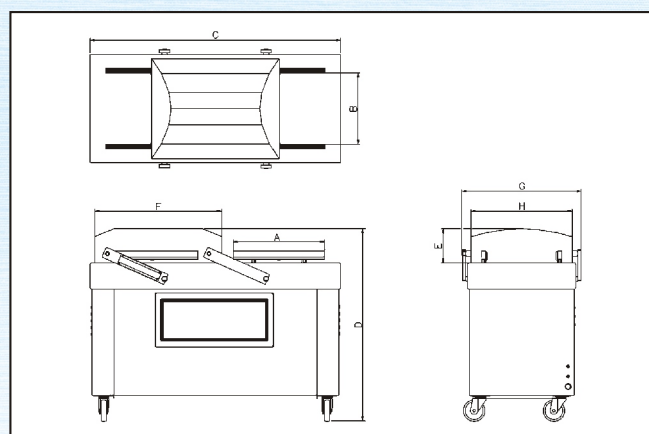

(pic#1)

(Pic#2)



DC-800 FB

All specifications are subject to change without notice.